



IMPUMP[®]

Intelligent Motor Pumps

www.imp-pumps.com



*Electronically controlled high-efficiency pumps
For heating, air conditioning, cooling and domestic water*



TECHNICAL DATA



INDEX

WHAT IS ErP REGULATION	PAGE 3
EXPLANATION OF THE TAG IMP PUMPS	PAGE 3
ABBREVIATIONS AND THEIR MEANINGS	PAGE 4
CONTACTS PAGE	PAGE 5
GENERAL INFORMATION PAGE	SEITE 5
HIGH-EFFICIENCY SCREW PUMPS	
NMT	FROM PAGE 6
NMT SMART	FROM PAGE 12
HIGH-EFFICIENCY PUMP FLANGE	
NMT SMART	FROM PAGE 20
NMT MAX	PAGE 28
NMT	FROM PAGE 30
NMT LAN	FROM PAGE 40
HIGH-EFFICIENCY PUMPS FOR HOT WATER	
ECO SAN	PAGE 48
INSTALLATION PAGE	PAGE 50
NOTES	PAGE 51

REGULATION ErP

WE ARE READY TO START

WITH HIGH-EFFICIENCY PUMPS AND AFFORDABLE PRICES

ErP Regulation (Energy related Products) translates as energy-relevant products. The objective of this Regulation, 2009 125 EC is to reduce energy consumption in accordance with the environmental requirements and it is being introduced in the EU in the field of circulation pumps in 2013. In the course of the next seven years the Regulation will be put in practice in the following three steps:

- The first step from 01/01/2013 for the energy index up to (max.) 0.27
- The second step from 01/08 in 2015 for the energy index up to (max.) 0.23
- The third step from 01/01/2020 for the energy index up to (max.) 0.23 – including the pumps, which are being replaced in HVAC systems



The IMP PUMPS meet environmental requirements in accordance to ERP Regulation with high-efficiency pumps with affordable prices.

EXPLANATION OF IMP PUMPS NAME TAG

NMT SMART 25 / 60 -180

NMT	new motor technology
SMART	series
25	nominal size
60	maximum pressure of 60
180	installation length

ABBREVIATIONS & THEIR MEANINGS

1 ~	Single-phase electric current
3 ~	3 phase electric current
DIN	Deutsches Institut für Normung
DN	nominal size of the connector
Δp	pressure difference
Δp -prop	proportional pressure difference
Δp -c	constant pressure difference
Δp -v	variable differential pressure
ECM-Technologie	BLDC synchronic motor with permanent magnets
EEL	energy class
ErP	ERP Regulation Energy related Products translated as energy corresponding products. The objective of this Regulation, 2009 125 EC is to reduce energy consumption. According to the environmental requirements of EuP 2005 32 EC
H	Pressure in meters
IP	Motor driven protection devices against environmental influences
ISO	EU standards
KTL-Beschichtung	Cataphoresis protection with high corrosion resistance
Modbus	The standard communication protocol
NMT	New motor technology
NMTC	New motor technology electronically, controlled circulation pump with communication module
NMTD	New motor technology electronically, controlled circulation pump in a double execution
NMT SAN	New motor technology High-efficiency circulating pump for domestic hot water
NMT ER	New motor technology electronically controlled circulation pump with analog signal 0 - 10 V
PN	Nominal pressure in bars
Q	Flow rate in cubic meters.
VDI-Guidelines	The flow in cubic meters per hour

CONTACTS

GENERAL MANAGER

Mr. Mag. Damir Popovic

e-mail: damir.popovic@imp-pumps.com

Tel: +386 1 2806 400

Fax: +386 1 2806 460



SALES MANAGER

Mr. Matjaž Kump

e-mail: matjaz.kump@imp-pumps.com

Tel: +386 1 2806 418

Fax: +386 1 2806 460



SALES OFFICE

Mrs. Martina Nartnik

e-mail: martina.nartnik@imp-pumps.com

Tel: +386 1 2806 414

Fax: +386 1 2806 460



TECHNICAL INFORMATION

Mr. Boris Petrovic

e-mail: boris.petrovic@imp-pumps.com

Tel: +386 1 2806 411

Fax: +386 1 2806 460



RESEARCH AND DEVELOPMENT

Mr. Janez Skander

e-mail: janez.skander@imp-pumps.com

Tel: +386 1 2806 426

Fax: +386 1 2806 460



FINANCE

Mr. Brigita Jankovič

e-mail: brigita.jankovic@imp-pumps.com

Tel: +386 1 2806 420

Fax: +386 1 2862 196



GENERAL INFORMATION

ALL PRODUCTS AND COMPONENTS ARE MANUFACTURED FROM ENVIRONMENTALLY FRIENDLY MATERIALS.

UPON DISPOSAL INTERNAL ENVIRONMENTAL REGULATION MUST BE CONSIDERED.

FURTHER INFORMATION ON ALL PUMPING PROGRAMS WITH TECHNICAL DATA ARE AVAILABLE ON
WWW.IMP-PUMPS.COM

GENERAL SALES CONDITIONS AND TERMS OF PAYMENT – DEPENDING ON THE AGREEMENT WITH THE FIRM IMP PUMPS.

TECHNICAL ADJUSTMENTS AND REVISIONS ARE NOT PERMITTED.



ECO HIGH-EFFICIENCY REGULATED THREADED PUMPS NMT -/40

NMT

PERFORMANCE

High efficiency ECM motor series pumps with canned motor and permanent magnets. Variable pressure control and constant speed. For use in water system according to requirements of VDI 2035.

APPLICATIONS FOR

All heating systems, air condition systems, closed loop cooling systems and industrial circulatory systems. The implementation bronze casing SAN for the usage in drinking water circulation systems.

OPERATION

Δp -Proportional pressure control

After selecting level pump recognizes the lowest resistance of the system and automatically adjusts its own strain.

Δp -Constant speed

After selection pump works in three different speeds

PRODUCT DESCRIPTION

- High efficiency ECM technology
- Energy savings
- Proportional pressure control
- Constant speed
- Easy handling and installation
- Robust and compact construction for long life
- Automatic venting
- Low noise operation
- Single body, which allows a variety of mounting positions
- Possibility of housing with cataphoretic
- The possibility of an analog input signal 0-10 V

Pump component	Material
Housing	Cast iron
Impeller	Polyamid
Shaft	Ceramics
Rotor can	Ceramics
Ventricular wall	Stainless steel
Rotor can	Stainless steel

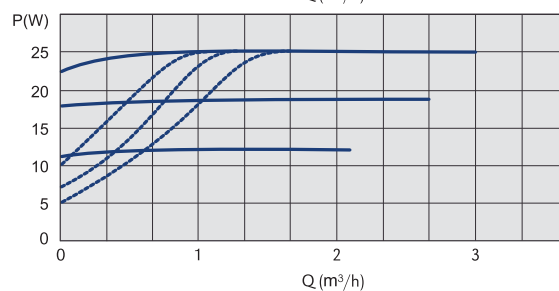
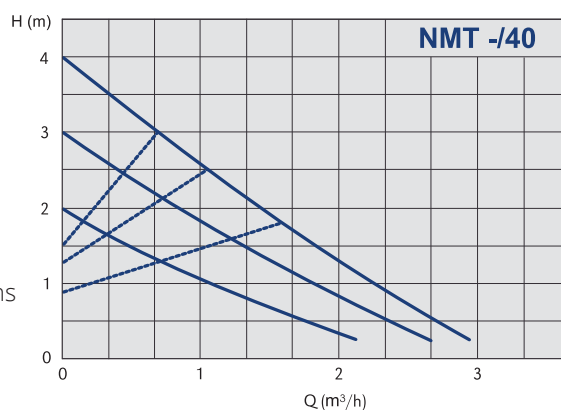

NMT	Pipe connection	DN	Fitting length	N. Pressure	Weight	Code	Euro
NMT 15/40-130	Rp ½	15	130 mm	PN 10 bar	1,9 kg	979522028	219,00 €
NMT 20/40-130	Rp ¾	20	130 mm	PN 10 bar	2,0 kg	979522024	219,00 €
NMT 25/40-130	Rp 1	25	130 mm	PN 10 bar	2,1 kg	979522025	219,00 €
NMT 20/40-180	Rp ¾	20	180 mm	PN 10 bar	2,3 kg	979522042	221,00 €
NMT 25/40-180	Rp 1	25	180 mm	PN 10 bar	2,4 kg	979522043	221,00 €
NMT 32/40-180	Rp 1 ¼	32	180 mm	PN 10 bar	2,5 kg	979522044	221,00 €
NMT SAN 20/40-130	Rp ¾	20	130 mm	PN 10 bar	2,1 kg	979523133	284,00 €
NMT SAN 25/40-130	Rp 1	25	130 mm	PN 10 bar	2,2 kg	979523134	284,00 €
NMT ER 15/40-130	Rp ½	15	130 mm	PN 10 bar	1,9 kg	979523143	272,00 €
NMT ER 20/40-130	Rp ¾	20	130 mm	PN 10 bar	2,0 kg	979523144	272,00 €
NMT ER 25/40-130	Rp 1	25	130 mm	PN 10 bar	2,1 kg	979523145	272,00 €
NMT ER 20/40-180	Rp ¾	20	180 mm	PN 10 bar	2,3 kg	979523146	273,00 €
NMT ER 25/40-180	Rp 1	25	180 mm	PN 10 bar	2,4 kg	979523147	273,00 €
NMT ER 32/40-180	Rp 1 ¼	32	180 mm	PN 10 bar	2,5 kg	979523148	273,00 €

Dimensions	L	DN	D2	b1	b2	l	a
NMT 40	130/180	15/20/25/32	1 1/5/4"/16/4"/2"	80	48	108	27/29/32

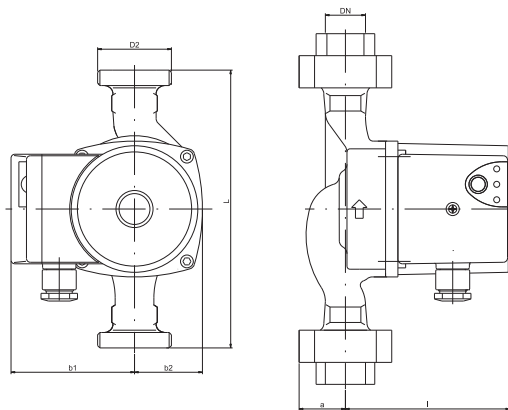

TECHNICAL DATA

Flow Q up to 2,6 m³/h
 Pressure H up to 4 m
 Power 5 - 25 Watt
 Nominal pressure 10 bar

Permissible mediums

- Water, mixed with glycol, parameters must be checked in the mixture of water with over 20% of glycol
- Pure non-explosive liquid media free from mineral oils and without solid particles

Permissible temperature range

- Medium temperature from +5 °C to +95 °C with max. surroundings temperature up to +40 °C

Minimum inlet pressure

0,05 bar < 75 °C Temperature of medium
 0,28 bar < 90 °C Temperature of medium

Electrical connection

Voltage 1 ~ 230 V, 50/60 Hz

Motor/Electronics

- Motor with permanent magnets
- The energy index EEI ≤ 0,20
- Built-in motor protection
- Control Δp or constant speed
- Degree of protection: IP 44
- Insulation class F
- Optional analog input signal 0 - 10 V



ECO HIGH-EFFICIENCY REGULATED THREADED PUMPS NMT -/60

NMT

PERFORMANCE

High efficiency ECM motor series pumps with canned motor and permanent magnets. Variable pressure control and constant speed. For use in water system according to requirements of VDI 2035.

APPLICATIONS FOR

All heating systems, air condition systems, closed loop cooling systems and industrial circulatory systems. The implementation bronze casing SAN for the usage in drinking water circulation systems.

OPERATION

Δp -Proportional pressure control

After selecting level pump recognizes the lowest resistance of the system and automatically adjusts its own strain.

Δp -Constant speed

After selection pump works in three different speeds

PRODUCT DESCRIPTION

- High efficiency ECM technology
- Energy savings
- Proportional pressure control
- Constant speed
- Easy handling and installation
- Robust and compact construction for long life
- Automatic venting
- Low noise operation
- Single body, which allows a variety of mounting positions
- Possibility of housing with cataphoretic
- The possibility of an analog input signal 0-10 V

Pump component	Material
Housing	Cast iron
Impeller	Polyamid
Shaft	Ceramics
Bearings	Ceramics
Ventricular wall	Stainless steel
Rotor can	Stainless steel

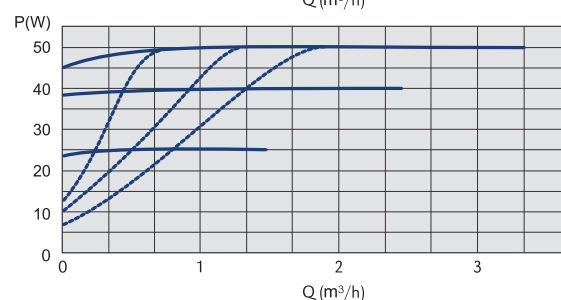
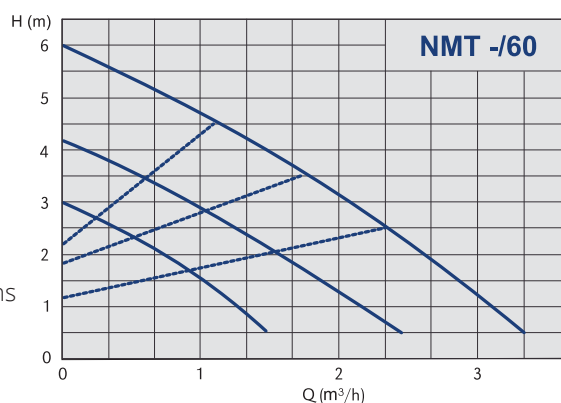

NMT	Pipe connection	DN	Fitting length	N. Pressure	Weight	Code	Euro
NMT 15/60-130	Rp ½	15	130 mm	PN 10 bar	1,9 kg	979522029	241,00 €
NMT 20/60-130	Rp ¾	20	130 mm	PN 10 bar	2,0 kg	979522026	241,00 €
NMT 25/60-130	Rp 1	25	130 mm	PN 10 bar	2,1 kg	979522027	241,00 €
NMT 20/60-180	Rp ¾	20	180 mm	PN 10 bar	2,3 kg	979522046	242,00 €
NMT 25/60-180	Rp 1	25	180 mm	PN 10 bar	2,4 kg	979522047	242,00 €
NMT 32/60-180	Rp 1 ¼	32	180 mm	PN 10 bar	2,5 kg	979522048	242,00 €
NMT SAN 20/60-130	Rp ¾	20	130 mm	PN 10 bar	2,1 kg	979523135	306,00 €
NMT SAN 25/60-130	Rp 1	25	130 mm	PN 10 bar	2,2 kg	979523136	306,00 €
NMT ER 15/60-130	Rp ½	15	130 mm	PN 10 bar	1,9 kg	979523149	293,00 €
NMT ER 20/60-130	Rp ¾	20	130 mm	PN 10 bar	2,0 kg	979523150	293,00 €
NMT ER 25/60-130	Rp 1	25	130 mm	PN 10 bar	2,1 kg	979523151	293,00 €
NMT ER 20/60-180	Rp ¾	20	180 mm	PN 10 bar	2,3 kg	979523152	295,00 €
NMT ER 25/60-180	Rp 1	25	180 mm	PN 10 bar	2,4 kg	979523153	295,00 €
NMT ER 32/60-180	Rp 1 ¼	32	180 mm	PN 10 bar	2,5 kg	979523154	295,00 €

Dimensions	L	DN	D2	b1	b2	l	a
NMT 60	130/180	15/20/25/32	1 1/5/4"/6/4"/2"	80	48	108	27/29/32

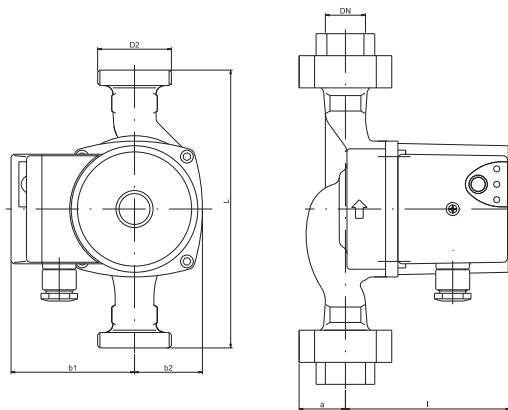

TECHNICAL DATA

Flow Q up to 3,7 m³/h
 Pressure H up to 6 m
 Power 7 - 50 Watt
 Nominal pressure 10 bar

Permissible mediums

- Water, mixed with glycol, parameters must be checked in the mixture of water with over 20% of glycol
- Pure non-explosive liquid media free from mineral oils and without solid particles

Permissible temperature range

- Medium temperature from +5 °C to +95 °C with max. surroundings temperature up to +40 °C

Minimum inlet pressure

0,05 bar < 75 °C Temperature of medium
 0,28 bar < 90 °C Temperature of medium

Electrical connection

Voltage 1 ~ 230 V, 50/60 Hz

Motor/Electronics

- Motor with permanent magnets
- The energy index EEI ≤ 0,22
- Built-in motor protection
- Control Δp or constant speed
- Degree of protection: IP 44
- Insulation class F
- Optional analog input signal 0 - 10 V



ECO HIGH-EFFICIENCY REGULATED THREADED PUMPS NMT -/80

NMT

PERFORMANCE

High efficiency ECM motor series pumps with canned motor and permanent magnets. Variable pressure control and constant speed. For use in water system according to requirements of VDI 2035.

APPLICATIONS FOR

All heating systems, air condition systems, closed loop cooling systems and industrial circulatory systems. The implementation bronze casing SAN for the usage in drinking water circulation systems.

OPERATION

Δp -Proportional pressure control

After selecting level pump recognizes the lowest resistance of the system and automatically adjusts its own strain.

Δp -Constant speed

After selection pump works in three different speeds

PRODUCT DESCRIPTION

- High efficiency ECM technology
- Energy savings
- Proportional pressure control
- Constant speed
- Easy handling and installation
- Robust and compact construction for long life
- Automatic venting
- Low noise operation
- Single body, which allows a variety of mounting positions
- Possibility of housing with cataphoretic
- The possibility of an analog input signal 0-10 V

Pump component	Material
Housing	Cast iron
Impeller	Polyamid
Shaft	Ceramics
Bearings	Ceramics
Ventricular wall	Stainless steel
Rotor can	Stainless steel

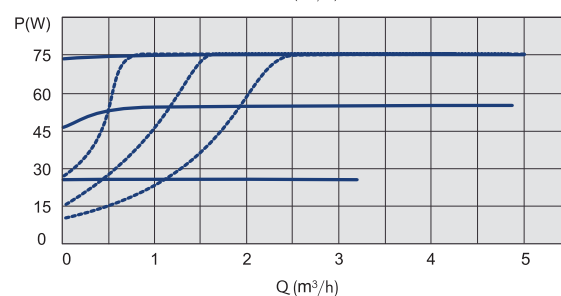
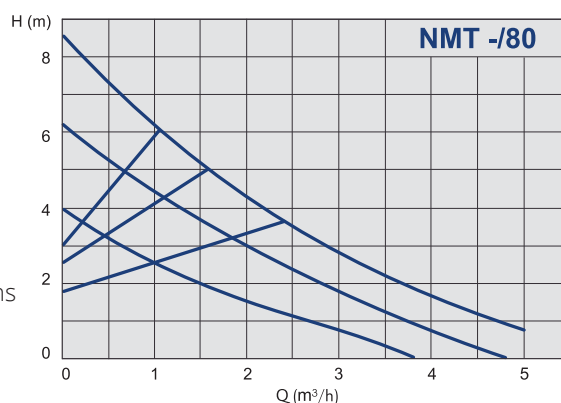

NMT	Pipe connection	DN	Fitting length	N. Pressure	Weight	Code	Euro
NMT 15/80-130	Rp ½	15	130 mm	PN 10 bar	1,9 kg	979522969	279,00 €
NMT 20/80-130	Rp ¾	20	130 mm	PN 10 bar	2,0 kg	979522970	279,00 €
NMT 25/80-130	Rp 1	25	130 mm	PN 10 bar	2,1 kg	979522971	279,00 €
NMT 20/80-180	Rp ¾	20	180 mm	PN 10 bar	2,3 kg	979522972	281,00 €
NMT 25/80-180	Rp 1	25	180 mm	PN 10 bar	2,4 kg	979522973	281,00 €
NMT 32/80-180	Rp 1 ¼	32	180 mm	PN 10 bar	2,5 kg	979522974	281,00 €
NMT SAN 20/80-130	Rp ¾	20	130 mm	PN 10 bar	2,1 kg	979523137	404,00 €
NMT SAN 25/80-130	Rp 1	25	130 mm	PN 10 bar	2,2 kg	979523138	404,00 €
NMT ER 15/80-130	Rp ½	15	130 mm	PN 10 bar	1,9 kg	979523155	331,00 €
NMT ER 20/80-130	Rp ¾	20	130 mm	PN 10 bar	2,0 kg	979523156	331,00 €
NMT ER 25/80-130	Rp 1	25	130 mm	PN 10 bar	2,1 kg	979523157	331,00 €
NMT ER 20/80-180	Rp ¾	20	180 mm	PN 10 bar	2,3 kg	979523158	333,00 €
NMT ER 25/80-180	Rp 1	25	180 mm	PN 10 bar	2,4 kg	979523159	333,00 €
NMT ER 32/80-180	Rp 1 ¼	32	180 mm	PN 10 bar	2,5 kg	979523160	333,00 €

Dimensions	L	DN	D2	b1	b2	l	a
NMT 80	130/180	15/20/25/32	1"/5/4"/6/4/2"	80	48	108	27/29/32

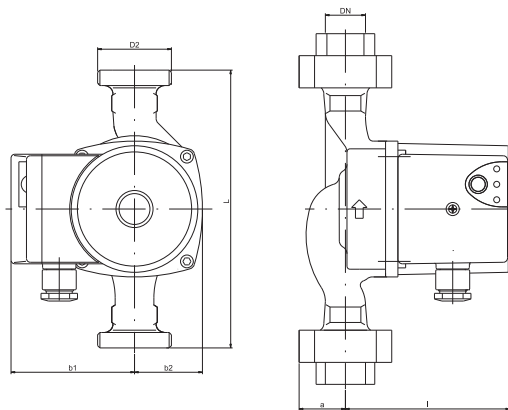

TECHNICAL DATA

Flow Q up to 4,5 m³/h
 Pressure H up to 8 m
 Power 7 - 75 Watt
 Nominal pressure 10 bar

Permissible mediums

- Water, mixed with glycol, parameters must be checked in the mixture of water with over 20% of glycol
- Pure non-explosive liquid media free from mineral oils and without solid particles

Permissible temperature range

- Medium temperature from +5 °C to +95 °C with max. surroundings temperature up to +40 °C

Minimum inlet pressure

0,05 bar < 75 °C Temperature of medium
 0,28 bar < 90 °C Temperature of medium

Electrical connection

Voltage 1 ~ 230 V, 50/60 Hz

Motor/Electronics

- Motor with permanent magnets
- The energy index EEI ≤ 0,24
- Built-in motor protection
- Control Δp or constant speed
- Degree of protection: IP 44
- Insulation class F
- Optional analog input signal 0 - 10 V



NEW

**HIGH-EFFICIENCY REGULATED
THREADED PUMPS NMT SMART 40** **SMART**

PERFORMANCE

High efficiency ECM motor series pumps with canned motor and permanent magnets. Variable and constant pressure control through display. For use in water system according to requirements of VDI 2035.

APPLICATIONS

All heating systems, air condition systems, closed loop cooling systems and industrial circulatory systems.

OPERATION

- Auto mode (default)
- Proportional pressure control
- Constant pressure control
- Constant speed
- Night mode

PRODUCT DESCRIPTION

- High efficiency ECM technology
- Energy savings
- LED Display for control
- Easy handling and installation
- Plug & Play
- Robust and compact construction for long life
- Automatic venting
- Low noise operation
- Possibility of housing with cataphoretic
- Possibility of NMTC communication module

Pump component	Material
Housing	Cast iron
Impeller	PES
Shaft	Stainless steel
Bearings	Graphite
Ventricular wall	Stainless steel
Rotor can	Stainless steel

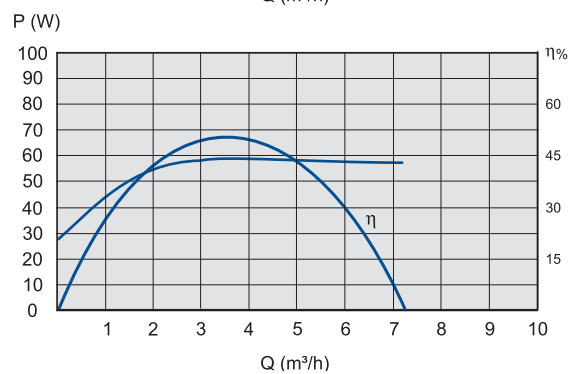
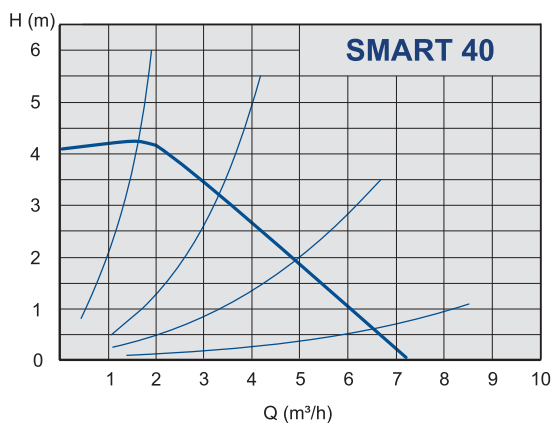

NMT	Pipe connection	DN	Fitting length	N. Pressure	Weight	Code	Euro
SMART 25-40	Rp 1	25	180 mm	PN 10 bar	4 kg	979523477	460,00 €
SMART 32-40	Rp 1 ¼	32	180 mm	PN 10 bar	4,1 kg	979523478	467,00 €
SMART C 25-40	Rp 1	25	180 mm	PN 10 bar	4,2 kg	979523488	603,00 €
SMART C 32-40	Rp 1 ¼	32	180 mm	PN 10 bar	4,3 kg	979523489	610,00 €

Dimensions	L	DN	D2	I
SMART 25-40	180	25	6/4"	190
SMART 32-40	180	32	2"	190
SMART C 25-40	180	25	6/4"	222
SMART C 32-40	180	32	2"	222

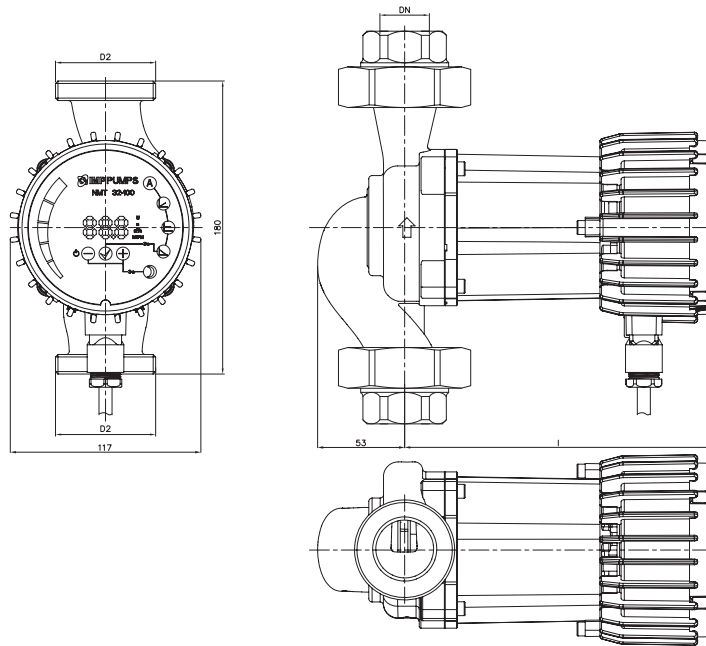

TECHNICAL DATA

Flow Q up to 7,5 m³/h
 Pressure H up to 4 m
 Power 7 - 60 Watt
 Nominal pressure 10 bar

Permissible mediums

- Water, mixed with glycol, parameters must be checked in the mixture of water with over 20% of glycol
- Pure non-explosive liquid media free from mineral oils and without solid particles

Permissible temperature range

- Medium temperature from +2 °C to +110 °C with max. surroundings temperature up to +40 °C

Minimum inlet pressure

0,05 bar < 75 °C Temperature of medium
 0,28 bar < 90 °C Temperature of medium

Electrical connection

Voltage 1 ~ 230 V, 50/60 Hz

Motor/Electronics

- Motor with permanent magnets
- The energy index EEI ≤ 0,21
- Built-in motor protection
- 3 control modes (proportional head, constant head, constant speed)
- Degree of protection: IP 44
- Insulation class F



NEW

HIGH-EFFICIENCY REGULATED

SMART

THREADED PUMPS NMT SMART 60

PERFORMANCE

High efficiency ECM motor series pumps with canned motor and permanent magnets. Variable and constant pressure control through display. For use in water system according to requirements of VDI 2035.

APPLICATIONS

All heating systems, air condition systems, closed loop cooling systems and industrial circulatory systems.

OPERATION

- Auto mode (default)
- Proportional pressure control
- Constant pressure control
- Constant speed
- Night mode

PRODUCT DESCRIPTION

- High efficiency ECM technology
- Energy savings
- LED Display for control
- Easy handling and installation
- Plug & Play
- Robust and compact construction for long life
- Automatic venting
- Low noise operation
- Possibility of housing with cataphoretic
- Possibility of NMTC communication module

Pump component	Material
Housing	Cast iron
Impeller	PES
Shaft	Stainless steel
Bearings	Graphite
Ventricular wall	Stainless steel
Rotor can	Stainless steel

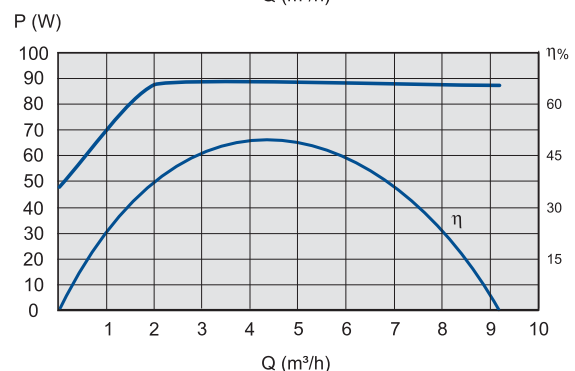
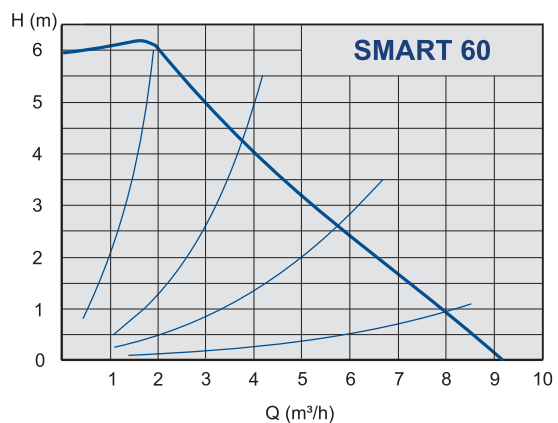

NMT	Pipe connection	DN	Fitting length	N. Pressure	Weight	Code	Euro
SMART 25-60	Rp 1	25	180 mm	PN 10 bar	4 kg	979523480	507,00 €
SMART 32-60	Rp 1 ¼	32	180 mm	PN 10 bar	4,1 kg	979523481	514,00 €
SMART C 25-60	Rp 1	25	180 mm	PN 10 bar	4,2 kg	979523491	650,00 €
SMART C 32-60	Rp 1 ¼	32	180 mm	PN 10 bar	4,3 kg	979523492	657,00 €

Dimensions	L	DN	D2	I
SMART 25-60	180	25	6/4"	190
SMART 32-60	180	32	2"	190
SMART C 25-60	180	25	6/4"	222
SMART C 32-60	180	32	2"	222

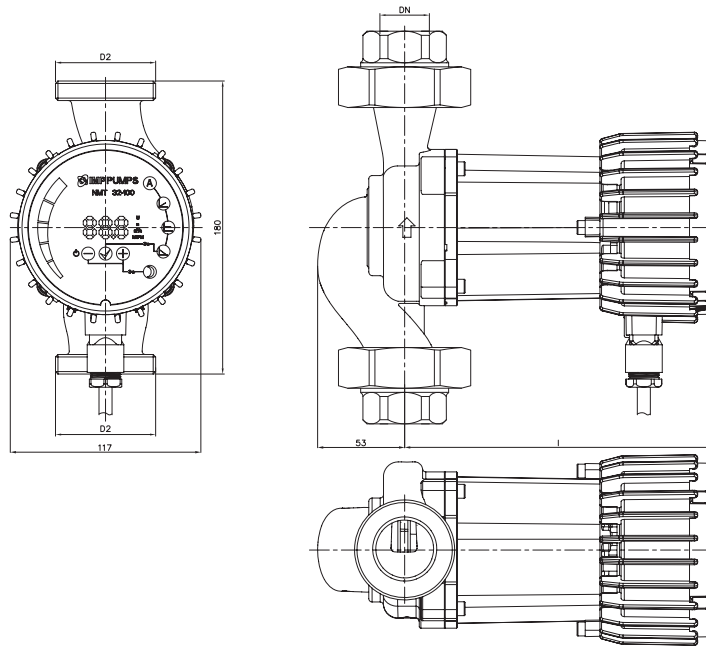

TECHNICAL DATA

Flow Q up to 9 m³/h
 Pressure H up to 6 m
 Power 7 - 90 Watt
 Nominal pressure 10 bar

Permissible mediums

- Water, mixed with glycol, parameters must be checked in the mixture of water with over 20% of glycol
- Pure non-explosive liquid media free from mineral oils and without solid particles

Permissible temperature range

- Medium temperature from +2 °C to +110 °C with max. surroundings temperature up to +40 °C

Minimum inlet pressure

0,05 bar < 75 °C Temperature of medium
 0,28 bar < 90 °C Temperature of medium

Electrical connection

Voltage 1 ~ 230 V, 50/60 Hz

Motor/Electronics

- Motor with permanent magnets
- The energy index EEI ≤ 0,21
- Built-in motor protection
- 3 control modes (proportional head, constant head, constant speed)
- Degree of protection: IP 44
- Insulation class F



NEW

HIGH-EFFICIENCY REGULATED

SMART

THREADED PUMPS NMT SMART 80

PERFORMANCE

High efficiency ECM motor series pumps with canned motor and permanent magnets. Variable and constant pressure control through display. For use in water system according to requirements of VDI 2035.

APPLICATIONS

All heating systems, air condition systems, closed loop cooling systems and industrial circulatory systems.

OPERATION

- Auto mode (default)
- Proportional pressure control
- Constant pressure control
- Constant speed
- Night mode

PRODUCT DESCRIPTION

- High efficiency ECM technology
- Energy savings
- LED Display for control
- Easy handling and installation
- Plug & Play
- Robust and compact construction for long life
- Automatic venting
- Low noise operation
- Possibility of housing with cataphoretic
- Possibility of NMT communication module

Pump component	Material
Housing	Cast iron
Impeller	PES
Shaft	Stainless steel
Bearings	Graphite
Ventricular wall	Stainless steel
Rotor can	Stainless steel

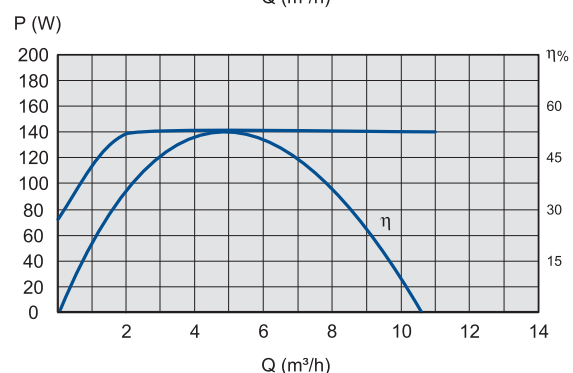
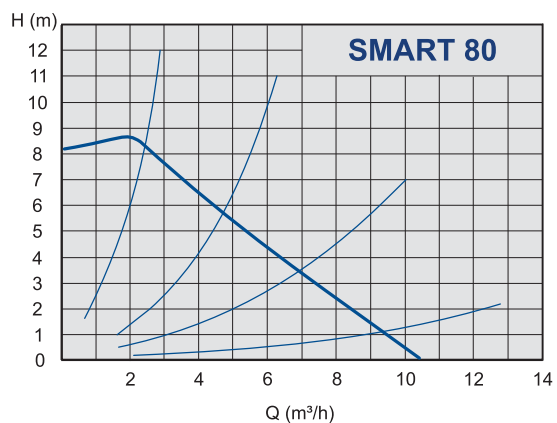

NMT	Pipe connection	DN	Fitting length	N. Pressure	Weight	Code	Euro
SMART 25-80	Rp 1	25	180 mm	PN 10 bar	4 kg	979523484	570,00 €
SMART 32-80	Rp 1 ¼	32	180 mm	PN 10 bar	4,1 kg	979523485	577,00 €
SMART C 25-80	Rp 1	25	180 mm	PN 10 bar	4,2 kg	979523495	713,00 €
SMART C 32-80	Rp 1 ¼	32	180 mm	PN 10 bar	4,3 kg	979523496	720,00 €

Dimensions	L	DN	D2	I
SMART 25-80	180	25	6/4"	190
SMART 32-80	180	32	2"	190
SMART C 25-80	180	25	6/4"	222
SMART C 32-80	180	32	2"	222

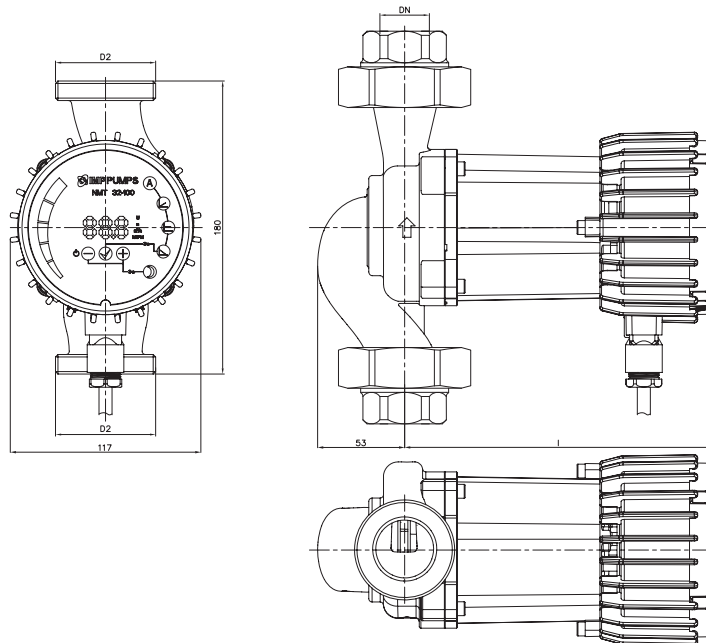

TECHNICAL DATA

Flow Q up to 10 m³/h
 Pressure H up to 8 m
 Power 7 - 140 Watt
 Nominal pressure 10 bar

Permissible mediums

- Water, mixed with glycol, parameters must be checked in the mixture of water with over 20% of glycol
- Pure non-explosive liquid media free from mineral oils and without solid particles

Permissible temperature range

- Medium temperature from +2 °C to +110 °C with max. surroundings temperature up to +40 °C

Minimum inlet pressure

0,05 bar < 75 °C Temperature of medium
 0,28 bar < 90 °C Temperature of medium

Electrical connection

Voltage 1 ~ 230 V, 50/60 Hz

Motor/Electronics

- Motor with permanent magnets
- The energy index EEI ≤ 0,21
- Built-in motor protection
- 3 control modes (proportional head, constant head, constant speed)
- Degree of protection: IP 44
- Insulation class F



NEW

HIGH-EFFICIENCY REGULATED

SMART

THREADED PUMPS NMT SMART 100

PERFORMANCE

High efficiency ECM motor series pumps with canned motor and permanent magnets. Variable and constant pressure control through display. For use in water system according to requirements of VDI 2035.

APPLICATIONS

All heating systems, air condition systems, closed loop cooling systems and industrial circulatory systems.

OPERATION

- Auto mode (default)
- Proportional pressure control
- Constant pressure control
- Constant speed
- Night mode

PRODUCT DESCRIPTION

- High efficiency ECM technology
- Energy savings
- LED Display for control
- Easy handling and installation
- Plug & Play
- Robust and compact construction for long life
- Automatic venting
- Low noise operation
- Possibility of housing with cataphoretic
- Possibility of NMTC communication module

Pump component	Material
Housing	Cast iron
Impeller	PES
Shaft	Stainless steel
Bearings	Graphite
Ventricular wall	Stainless steel
Rotor can	Stainless steel

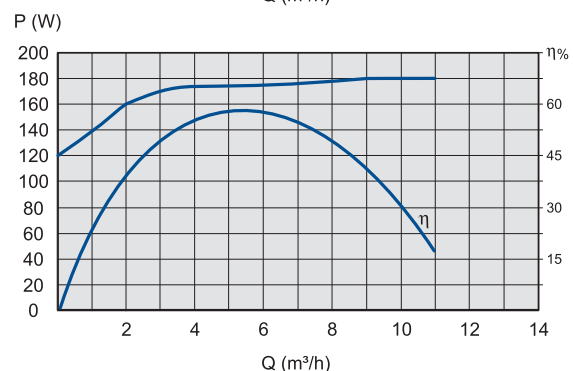
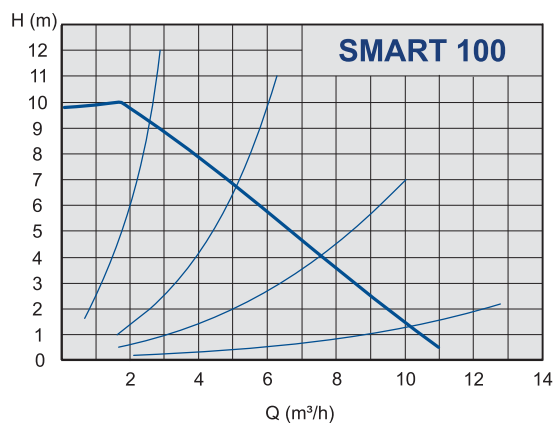

NMT	Pipe connection	DN	Fitting length	N. Pressure	Weight	Code	Euro
SMART 25-100	Rp 1	25	180 mm	PN 10 bar	4 kg	979523301	577,00 €
SMART 32- 100	Rp 1 ¼	32	180 mm	PN 10 bar	4,1 kg	979523216	584,00 €
SMART C 25-100	Rp 1	25	180 mm	PN 10 bar	4,2 kg	979523371	720,00 €
SMART C 32-100	Rp 1 ¼	32	180 mm	PN 10 bar	4,3 kg	979523367	727,00 €

Dimensions	L	DN	D2	I
SMART 25-100	180	25	6/4"	190
SMART 32- 100	180	32	2"	190
SMART C 25-100	180	25	6/4"	222
SMART C 32-100	180	32	2"	222

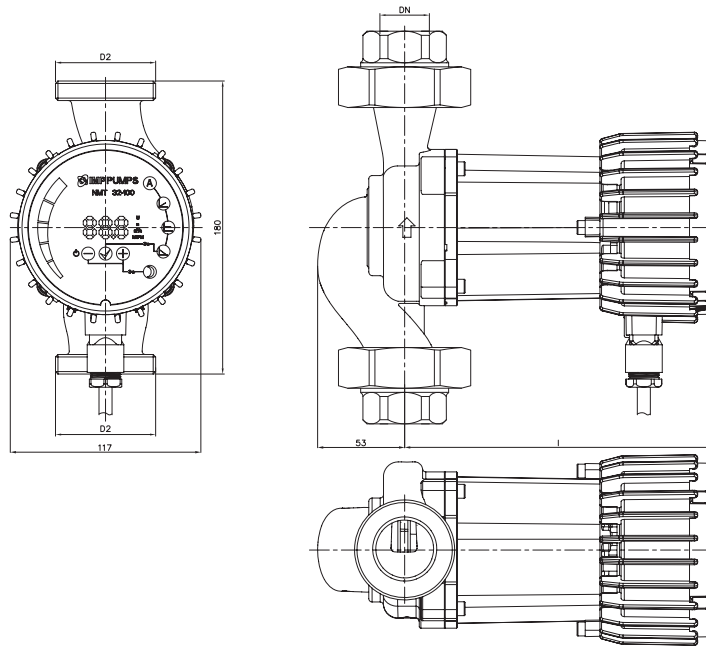

TECHNICAL DATA

Flow Q up to 11 m³/h
 Pressure H up to 10 m
 Power 7 - 180 Watt
 Nominal pressure 10 bar

Permissible mediums

- Water, mixed with glycol, parameters must be checked in the mixture of water with over 20% of glycol
- Pure non-explosive liquid media free from mineral oils and without solid particles

Permissible temperature range

- Medium temperature from +2 °C to +110 °C with max. surroundings temperature up to +40 °C

Minimum inlet pressure

0,05 bar < 75 °C Temperature of medium
 0,28 bar < 90 °C Temperature of medium

Electrical connection

Voltage 1 ~ 230 V, 50/60 Hz

Motor/Electronics

- Motor with permanent magnets
- The energy index EEI ≤ 0,21
- Built-in motor protection
- 3 control modes (proportional head, constant head, constant speed)
- Degree of protection: IP 44
- Insulation class F



HIGH-EFFICIENCY REGULATED

SMART

FLANGED PUMP NMT SMART 40 F

PERFORMANCE

High efficiency ECM motor series pumps with canned motor and permanent magnets. Variable and constant pressure control through display. For use in water system according to requirements of VDI 2035.

APPLICATIONS

All heating systems, air condition systems, closed loop cooling systems and industrial circulatory systems.

OPERATION

- Auto mode (default)
- Proportional pressure control
- Constant pressure control
- Constant speed
- Night mode

PRODUCT DESCRIPTION

- High efficiency ECM technology
- Energy savings
- LED Display for control
- Easy handling and installation
- Plug & Play
- Robust and compact construction for long life
- Automatic venting
- Low noise operation
- Possibility of housing with cataphoretic
- Possibility of NMT communication module

Pump component	Material
Housing	Cast iron
Impeller	PES
Shaft	Stainless steel
Bearings	Graphite
Ventricular wall	Stainless steel
Rotor can	Stainless steel

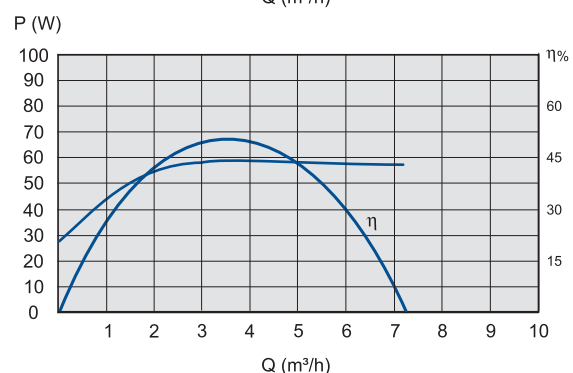
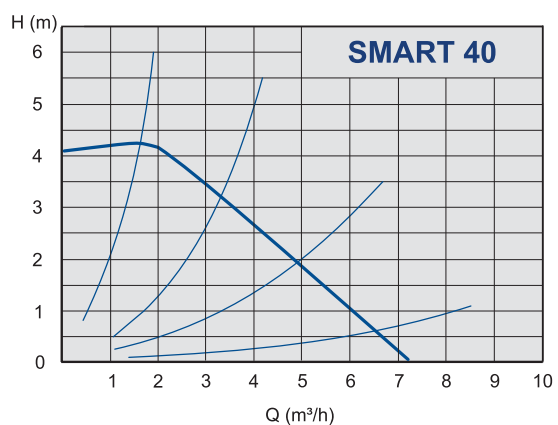

NMT	DN	Fitting length	N. Pressure	Weight	Code	Euro
SMART 32-40 F	32	220 mm	PN 10	7,4 kg	979523479	486,00 €
SMART C 32-40 F	32	220 mm	PN 10	7,6 kg	979523490	629,00 €

Dimensions	h	DN	b1	l	a
SMART 32-40 F	220	32	117	190	70
SMART C 32-40 F	220	32	117	222	70

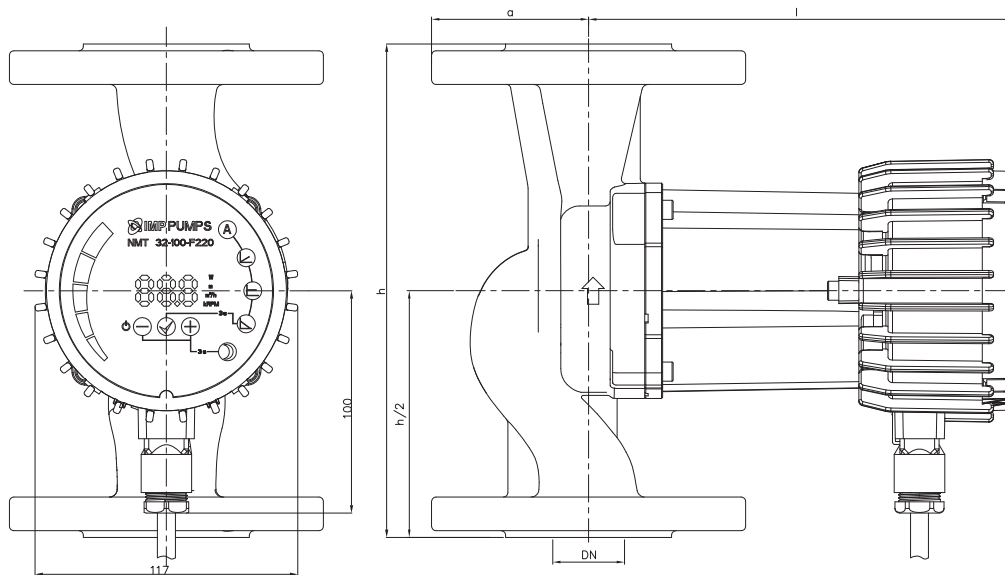

TECHNICAL DATA

Flow Q up to 7,5 m³/h
 Pressure H up to 4 m
 Power 7 - 60 Watt
 Nominal pressure 10 bar

Permissible mediums

- Water, mixed with glycol, parameters must be checked in the mixture of water with over 20% of glycol
- Pure non-explosive liquid media free from mineral oils and without solid particles

Permissible temperature range

- Medium temperature from +2 °C to +110 °C with max. surroundings temperature up to +40 °C

Minimum inlet pressure

0,05 bar < 75 °C Temperature of medium
 0,28 bar < 90 °C Temperature of medium

Electrical connection

Voltage 1 ~ 230 V, 50/60 Hz

Motor/Electronics

- Motor with permanent magnets
- The energy index EEI ≤ 0,21
- Built-in motor protection
- 3 control modes (proportional head, constant head, constant speed)
- Degree of protection: IP 44
- Insulation class F



HIGH-EFFICIENCY REGULATED

SMART

FLANGED PUMP NMT SMART 60 F

PERFORMANCE

High efficiency ECM motor series pumps with canned motor and permanent magnets. Variable and constant pressure control through display. For use in water system according to requirements of VDI 2035.

APPLICATIONS

All heating systems, air condition systems, closed loop cooling systems and industrial circulatory systems.

OPERATION

- Auto mode (default)
- Proportional pressure control
- Constant pressure control
- Constant speed
- Night mode

PRODUCT DESCRIPTION

- High efficiency ECM technology
- Energy savings
- LED Display for control
- Easy handling and installation
- Plug & Play
- Robust and compact construction for long life
- Automatic venting
- Low noise operation
- Possibility of housing with cataphoretic
- Possibility of NMT communication module

Pump component	Material
Housing	Cast iron
Impeller	PES
Shaft	Stainless steel
Bearings	Graphite
Ventricular wall	Stainless steel
Rotor can	Stainless steel

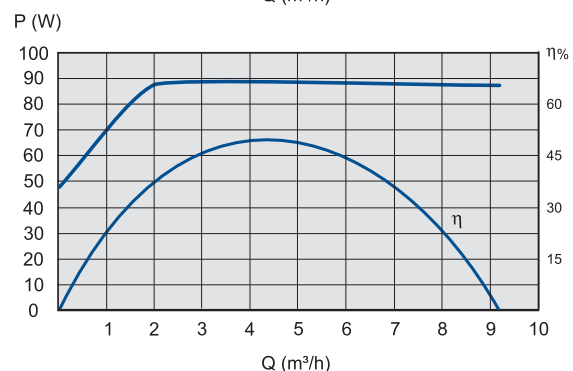
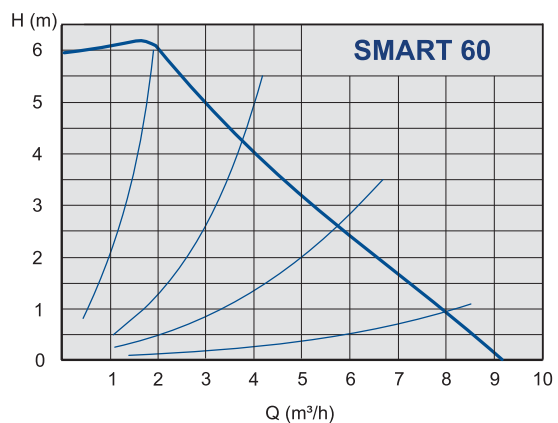

NMT	DN	Fitting length	N. Pressure	Weight	Code	Euro
SMART 32-60 F	32	220 mm	PN 10	7,4 kg	979523482	533,00 €
SMART 40-60 F	40	220 mm	PN 10	8,5 kg	979523483	589,00 €
SMART C 32-60 F	32	220 mm	PN 10	7,6 kg	979523493	676,00 €
SMART C 40-60 F	40	220 mm	PN 10	8,7 kg	979523494	732,00 €

Dimensions	h	DN	b1	l	a
SMART 32-60 F	220	32	117	190	70
SMART 40-60 F	220	40	117	190	75
SMART C 32-60 F	220	32	117	222	70
SMART C 40-60 F	220	40	117	222	75

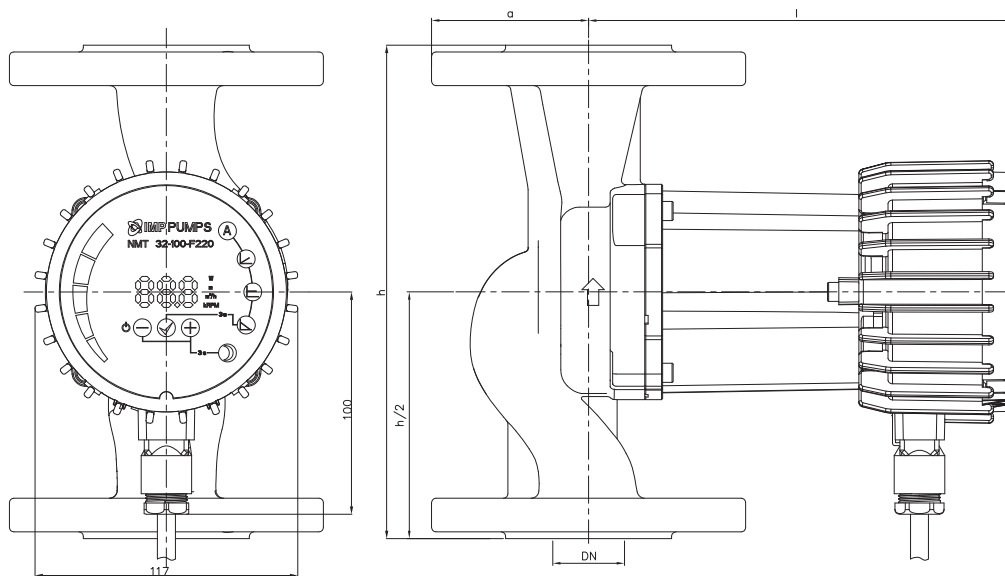

TECHNICAL DATA

Flow Q up to 9 m³/h
 Pressure H up to 6 m
 Power 7 - 90 Watt
 Nominal pressure 10 bar

Permissible mediums

- Water, mixed with glycol, parameters must be checked in the mixture of water with over 20% of glycol
- Pure non-explosive liquid media free from mineral oils and without solid particles

Permissible temperature range

- Medium temperature from +2 °C to +110 °C with max. surroundings temperature up to +40 °C

Minimum inlet pressure

0,05 bar < 75 °C Temperature of medium
 0,28 bar < 90 °C Temperature of medium

Electrical connection

Voltage 1 ~ 230 V, 50/60 Hz

Motor/Electronics

- Motor with permanent magnets
- The energy index EEI ≤ 0,21
- Built-in motor protection
- 3 control modes (proportional head, constant head, constant speed)
- Degree of protection: IP 44
- Insulation class F



HIGH-EFFICIENCY REGULATED

SMART

FLANGED PUMP NMT SMART 80 F

PERFORMANCE

High efficiency ECM motor series pumps with canned motor and permanent magnets. Variable and constant pressure control through display. For use in water system according to requirements of VDI 2035.

APPLICATIONS

All heating systems, air condition systems, closed loop cooling systems and industrial circulatory systems.

OPERATION

- Auto mode (default)
- Proportional pressure control
- Constant pressure control
- Constant speed
- Night mode

PRODUCT DESCRIPTION

- High efficiency ECM technology
- Energy savings
- LED Display for control
- Easy handling and installation
- Plug & Play
- Robust and compact construction for long life
- Automatic venting
- Low noise operation
- Possibility of housing with cataphoretic
- Possibility of NMT communication module

Pump component	Material
Housing	Cast iron
Impeller	PES
Shaft	Stainless steel
Bearings	Graphite
Ventricular wall	Stainless steel
Rotor can	Stainless steel

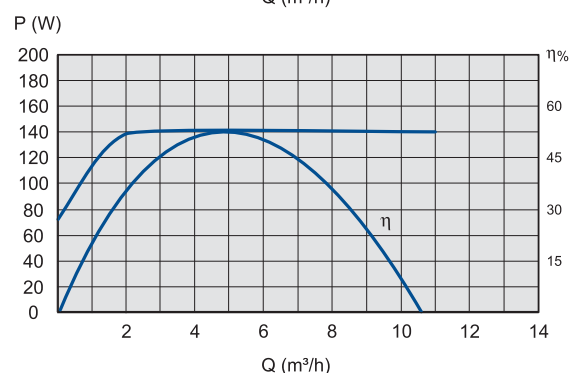
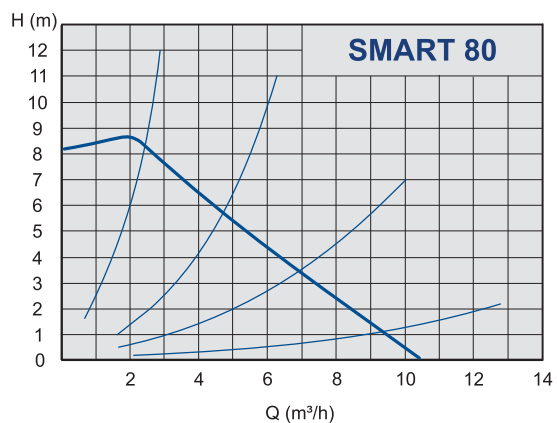

NMT	DN	Fitting length	N. Pressure	Weight	Code	Euro
SMART 32-80 F	32	220 mm	PN 10	7,4 kg	979523486	596,00 €
SMART 40-80 F	40	220 mm	PN 10	8,5 kg	979523487	652,00 €
SMART C 32-80 F	32	220 mm	PN 10	7,6 kg	979523497	739,00 €
SMART C 40-80 F	40	220 mm	PN 10	8,7 kg	979523498	795,00 €

Dimensions	h	DN	b1	l	a
SMART 32-80 F	220	32	117	190	70
SMART 40-80 F	220	40	117	190	75
SMART C 32-80 F	220	32	117	222	70
SMART C 40-80 F	220	40	117	222	75

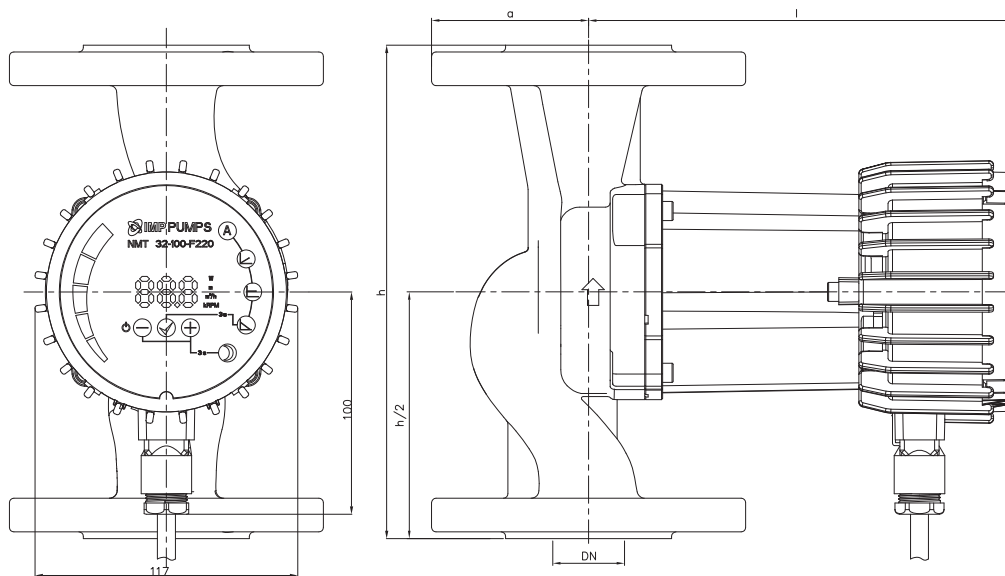

TECHNICAL DATA

Flow Q up to 10 m³/h
 Pressure H up to 8 m
 Power 7 - 60 Watt
 Nominal pressure 10 bar

Permissible mediums

- Water, mixed with glycol, parameters must be checked in the mixture of water with over 20% of glycol
- Pure non-explosive liquid media free from mineral oils and without solid particles

Permissible temperature range

- Medium temperature from +2 °C to +110 °C with max. surroundings temperature up to +40 °C

Minimum inlet pressure

0,05 bar < 75 °C Temperature of medium
 0,28 bar < 90 °C Temperature of medium

Electrical connection

Voltage 1 ~ 230 V, 50/60 Hz

Motor/Electronics

- Motor with permanent magnets
- The energy index EEI ≤ 0,21
- Built-in motor protection
- 3 control modes (proportional head, constant head, constant speed)
- Degree of protection: IP 44
- Insulation class F



HIGH-EFFICIENCY REGULATED

SMART

FLANGED PUMP NMT SMART 100 F

PERFORMANCE

High efficiency ECM motor series pumps with canned motor and permanent magnets. Variable and constant pressure control through display. For use in water system according to requirements of VDI 2035.

APPLICATIONS

All heating systems, air condition systems, closed loop cooling systems and industrial circulatory systems.

OPERATION

- Auto mode (default)
- Proportional pressure control
- Constant pressure control
- Constant speed
- Night mode

PRODUCT DESCRIPTION

- High efficiency ECM technology
- Energy savings
- LED Display for control
- Easy handling and installation
- Plug & Play
- Robust and compact construction for long life
- Automatic venting
- Low noise operation
- Possibility of housing with cataphoretic
- Possibility of NMT communication module

Pump component	Material
Housing	Cast iron
Impeller	PES
Shaft	Stainless steel
Bearings	Graphite
Ventricular wall	Stainless steel
Rotor can	Stainless steel

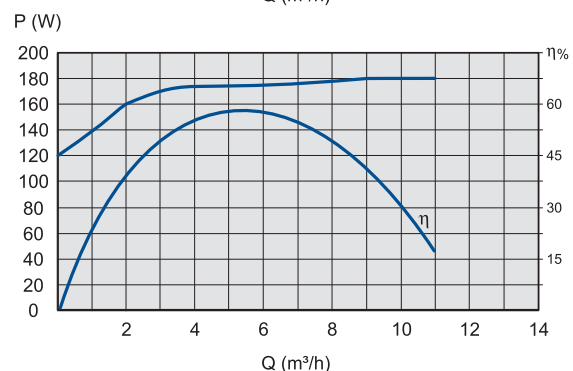
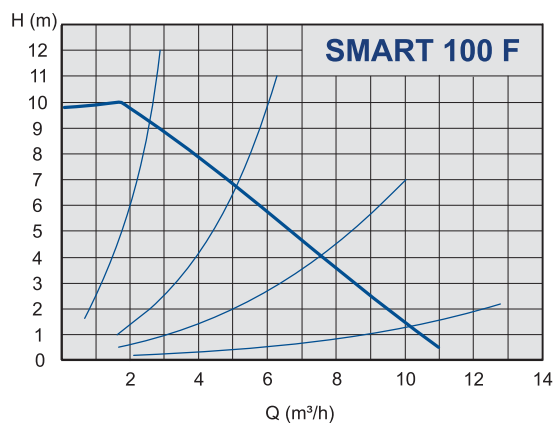

NMT	DN	Fitting length	N. Pressure	Weight	Code	Euro
SMART 32-100 F	32	220 mm	PN 10	7,4 kg	979523284	603,00 €
SMART 40- 100 F	40	220 mm	PN 10	8,5 kg	979523285	659,00 €
SMART 50-100 F	50	240 mm	PN 10	9,8 kg	979523286	707,00 €
SMART C 32-100 F	32	220 mm	PN 10	7,6 kg	979523368	746,00 €
SMART C 40-100 F	40	220 mm	PN 10	8,7 kg	979523369	802,00 €
SMART C 50-100 F	50	240 mm	PN 10	10 kg	979523370	850,00 €

Dimensions	h	DN	b1	l	a
SMART 32-100 F	220	32	117	190	70
SMART 40- 100 F	220	40	117	190	75
SMART 50-100 F	240	50	117	190	82,5
SMART C 32-100 F	220	32	117	222	70
SMART C 40-100 F	220	40	117	222	75
SMART C 50-100 F	240	50	117	222	82,5

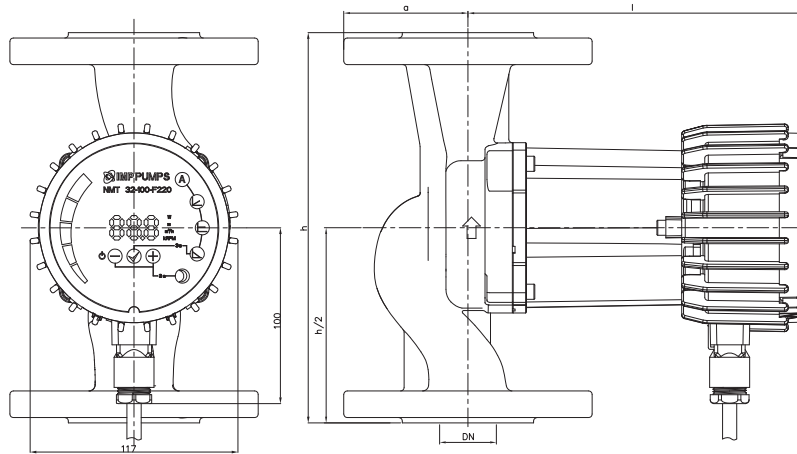

TECHNICAL DATA

Flow Q up to 11 m³/h
 Pressure H up to 10 m
 Power 7 - 180 Watt
 Nominal pressure 10 bar

Permissible mediums

- Water, mixed with glycol, parameters must be checked in the mixture of water with over 20% of glycol
- Pure non-explosive liquid media free from mineral oils and without solid particles

Permissible temperature range

- Medium temperature from +2 °C to +110 °C with max. surroundings temperature up to +40 °C

Minimum inlet pressure

0,05 bar < 75 °C Temperature of medium
 0,28 bar < 90 °C Temperature of medium

Electrical connection

Voltage 1 ~ 230 V, 50/60 Hz

Motor/Electronics

- Motor with permanent magnets
- The energy index EEI ≤ 0,21
- Built-in motor protection
- 3 control modes (proportional head, constant head, constant speed)
- Degree of protection: IP 44
- Insulation class F



NEW

HIGH-EFFICIENCY REGULATED FLANGED PUMP NMT MAX 120 F

MAX

PERFORMANCE

High efficiency ECM motor series pumps with canned motor and permanent magnets. Variable and constant pressure control through display. For use in water system according to requirements of VDI 2035.

APPLICATIONS

All heating systems, air condition systems, closed loop cooling systems and industrial circulatory systems.

OPERATION

- Auto mode (default)
- Proportional pressure control
- Constant pressure control
- Constant speed
- Night mode

PRODUCT DESCRIPTION

- High efficiency ECM technology
- Energy savings
- LED Display for control
- Easy handling and installation
- Plug & Play
- Robust and compact construction for long life
- Automatic venting
- Low noise operation
- Possibility of housing with cataphoretic
- Possibility of NMTC communication module

Pump component	Material
Housing	Cast iron
Impeller	PES
Shaft	Stainless steel
Bearings	Graphite
Ventricular wall	Stainless steel
Rotor can	Stainless steel

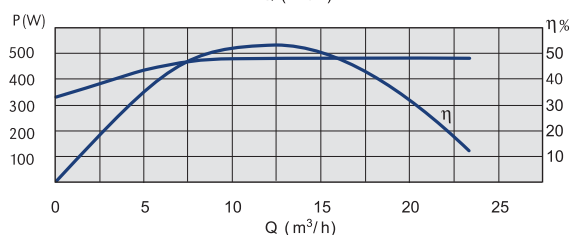
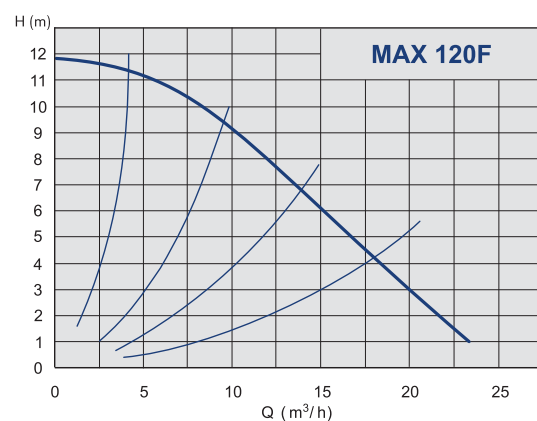

NMT	DN	Fitting length	N. Pressure	Weight	Code	Euro
MAX 40 - 120 F	40	250 mm	PN 10	9,0 kg	979523502	2013
MAX C 40 - 120 F	40	250 mm	PN 10	9,4 kg	979523503	2013

Dimensions	h	DN	b1	l	a
MAX 40 - 120 F	250	40	146	282	65
MAX C 40 - 120 F	250	40	146	260	65

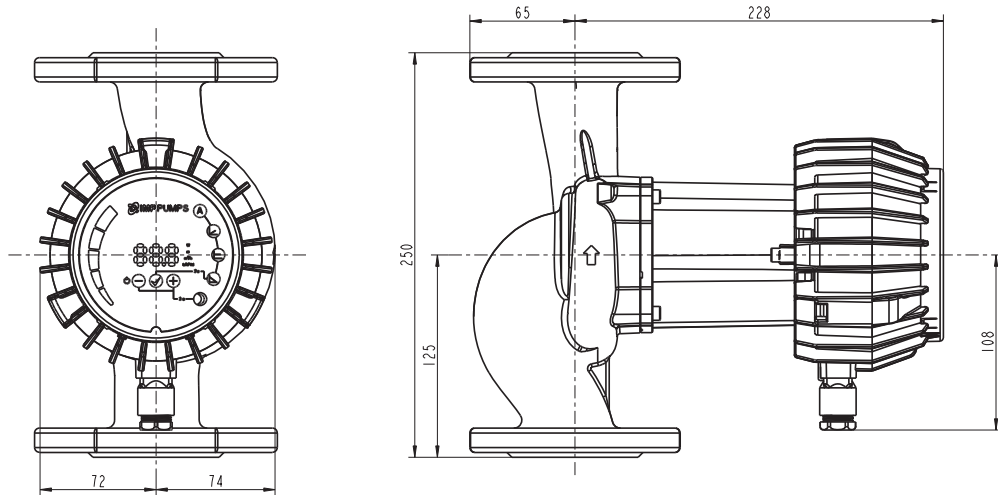

TECHNICAL DATA

Flow Q up to 23 m³/h
 Pressure H up to 12 m
 Power 25 - 480 Watt
 Nominal pressure PN 6/10 bar

Permissible mediums

- Water, mixed with glycol, parameters must be checked in the mixture of water with over 20% of glycol
- Pure non-explosive liquid media free from mineral oils and without solid particles

Permissible temperature range

- Medium temperature from +2 °C to +110 °C with max. surroundings temperature up to +40 °C

Minimum inlet pressure

0,05 bar < 75 °C Temperature of medium
 0,28 bar < 90 °C Temperature of medium

Electrical connection

Voltage 1 ~ 230 V, 50/60 Hz

Motor/Electronics

- Motor with permanent magnets
- The energy index EEI ≤ 0,21
- Built-in motor protection
- Degree of protection: IP 44
- Insulation class F



HIGH-EFFICIENCY REGULATED FLANGED PUMP NMT 40 F

NMT

PERFORMANCE

High efficiency ECM motor series pumps with canned motor and permanent magnets. Variable and constant pressure control through Ethernet connection. For use in water system according to requirements of VDI 2035.

APPLICATIONS

Heating system, air condition systems, closed loop cooling system and industrial circulatory systems. With bronze casting - SAN version, for use in drinking water circulation systems.

OPERATION

Δp -Proportional pressure control

The pump proportionally adjust the pressure, according to system resistance. Guaranteeing minimal power and energy consumptions.

PRODUCT DESCRIPTION

- Efficiency ECM technology
- Energy savings
- Easy handling and installation
- Robust and compact construction for long life
- Automatic venting
- Silent operation
- Possibility of housing with cataphoresis
- Twin pump option
- Twin pump option with SAN - bronze housing

Pump component	Material
Housing	Cast iron
Impeller	Stainless steel
Shaft	Stainless steel
Bearings	Graphite
Separating bush	Stainless steel
Rotor can	Stainless steel

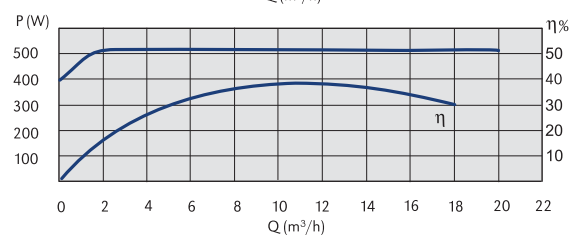
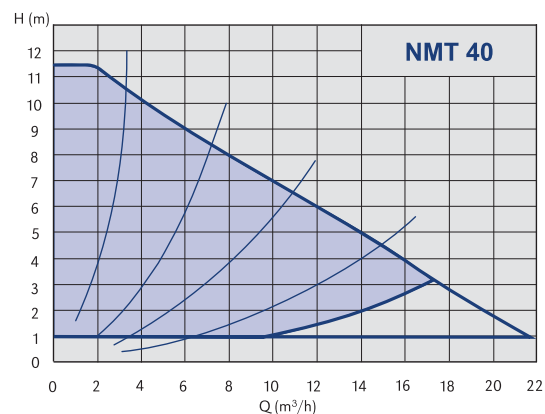

NMT	DN	Fitting length	N. Pressure	Weight	Code	Euro
NMT 40	40	250 mm	PN 6/10 bar	24 kg	979522736	1.308,00 €
NMTD 40	40	250 mm	PN 6/10 bar	47 kg	979522744	2.342,00 €
NMT SAN 40	40	250 mm	PN 6/10 bar	26 kg	979523199	1.932,00 €

Dimensions	h	DN	b1	b4	l	a
NMT 40	250	40	189		321	65
NMTD 40	250	40		403	321	65
NMT SAN 40	250	40	189		321	65

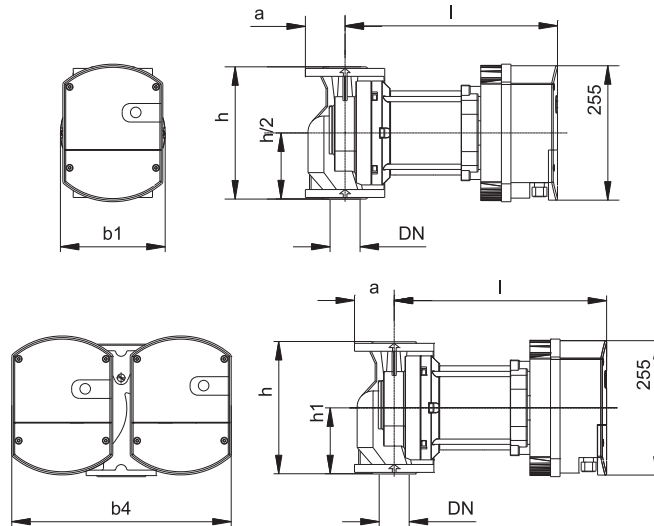

TECHNICAL DATA

Flow Q up to 25 m³/h
 Pressure H up to 13 m
 Power 20 - 500 Watt
 Nominal pressure 6/10 bar

Permissible mediums

- Water, mixed with glycol, parameters must be checked in the mixture of water with over 20% of glycol
- Pure non-explosive liquid media free from mineral oils and without solid particles

Permissible temperature range

- Medium temperature from -10 °C to +110 °C with max. surroundings temperature up to +40 °C

Minimum inlet pressure

0,5 bar < 50°C Temperature of medium
 0,8 bar < 80°C Temperature of medium
 1,4 bar < 110°C Temperature of medium

Electrical connection

Voltage 1 ~ 230 V, 50/60 Hz

Motor/Electronics

- Motor with permanent magnets
- The energy index EEI ≤ 0,27
- Built-in motor protection
- Methods of control:
 - Current control (limit current)
 - Power control (limit power)
 - Constant pressure control (Δp-c)
 - Proportional pressure control (Δp-v)
 - Option settings QH curve at fixed speeds
 - Constant speed
- Degree of protection: IP 44
- Insulation class H



HIGH-EFFICIENCY REGULATED FLANGED PUMP NMT 50 F

NMT

PERFORMANCE

High efficiency ECM motor series pumps with canned motor and permanent magnets. Variable and constant pressure control through Ethernet connection. For use in water system according to requirements of VDI 2035.

APPLICATIONS

Heating system, air condition systems, closed loop cooling system and industrial circulatory systems. With bronze casting - SAN version, for use in drinking water circulation systems.

OPERATION

Δp -Proportional pressure control

The pump proportionally adjust the pressure, according to system resistance. Guaranteeing minimal power and energy consumptions.

PRODUCT DESCRIPTION

- Efficiency ECM technology
- Energy savings
- Easy handling and installation
- Robust and compact construction for long life
- Automatic venting
- Silent operation
- Possibility of housing with cataphoresis
- Twin pump option
- Twin pump option with SAN - bronze housing

Pump component	Material
Housing	Cast iron
Impeller	Stainless steel
Shaft	Stainless steel
Bearings	Graphite
Separating bush	Stainless steel
Rotor can	Stainless steel

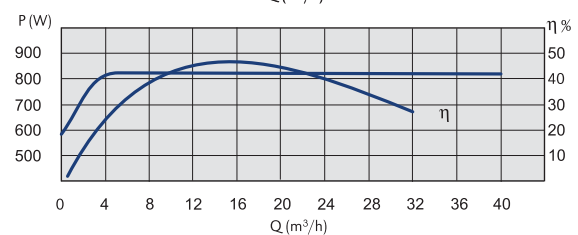
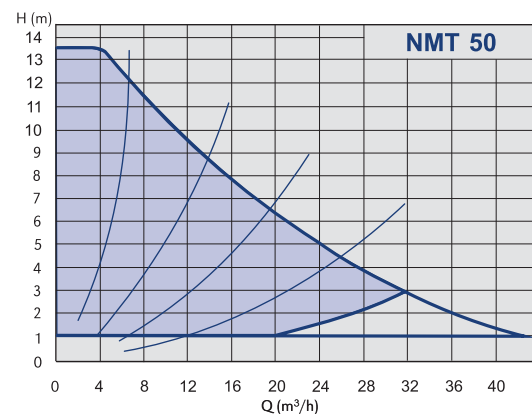

NMT	DN	Fitting length	N. Pressure	Weight	Code	Euro
NMT 50	50	280 mm	PN 6/10 bar	31 kg	979522737	1.560,00 €
NMTD 50	50	280 mm	PN 6/10 bar	60 kg	979522745	2.917,00 €
NMT SAN 50	50	280 mm	PN 6/10 bar	33 kg	979523200	2.231,00 €

Dimensions	h	DN	b1	b4	l	a
NMT 50	280	50	189		355	70
NMTD 50	280	50		403	355	70
NMT SAN 50	280	50	189		355	70

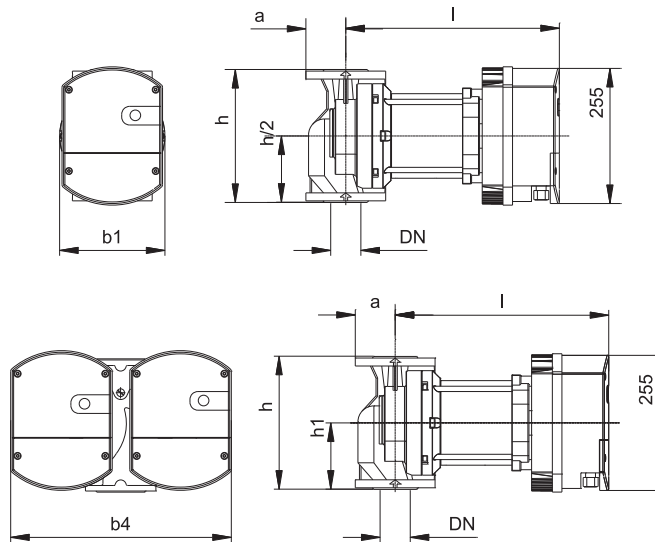

TECHNICAL DATA

Flow Q up to 39 m³/h
 Pressure H up to 13 m
 Power 26 - 800 Watt
 Nominal pressure 6/10 bar

Permissible mediums

- Water, mixed with glycol, parameters must be checked in the mixture of water with over 20% of glycol
- Pure non-explosive liquid media free from mineral oils and without solid particles

Permissible temperature range

- Medium temperature from -10 °C to +110 °C with max. surroundings temperature up to +40 °C

Minimum inlet pressure

0,5 bar < 50°C Temperature of medium
 0,8 bar < 80°C Temperature of medium
 1,4 bar < 110°C Temperature of medium

Electrical connection

Voltage 1 ~ 230 V, 50/60 Hz

Motor/Electronics

- Motor with permanent magnets
- The energy index EEI ≤ 0,26
- Built-in motor protection
- Methods of control:
 - Current control (limit current)
 - Power control (limit power)
 - Constant pressure control (Δp-c)
 - Proportional pressure control (Δp-v)
 - Option settings QH curve at fixed speeds
 - Constant speed
- Degree of protection: IP 44
- Insulation class H



HIGH-EFFICIENCY REGULATED FLANGED PUMP NMT 65 F

NMT

PERFORMANCE

High efficiency ECM motor series pumps with canned motor and permanent magnets. Variable and constant pressure control through Ethernet connection. For use in water system according to requirements of VDI 2035.

APPLICATIONS

Heating system, air condition systems, closed loop cooling system and industrial circulatory systems. With bronze casting - SAN version, for use in drinking water circulation systems.

OPERATION

Δp -Proportional pressure control

The pump proportionally adjust the pressure, according to system resistance. Guaranteeing minimal power and energy consumptions.

PRODUCT DESCRIPTION

- Efficiency ECM technology
- Energy savings
- Easy handling and installation
- Robust and compact construction for long life
- Automatic venting
- Silent operation
- Possibility of housing with cataphoresis
- Twin pump option
- Twin pump option with SAN - bronze housing

Pump component	Material
Housing	Cast iron
Impeller	Stainless steel
Shaft	Stainless steel
Bearings	Graphite
Separating bush	Stainless steel
Rotor can	Stainless steel

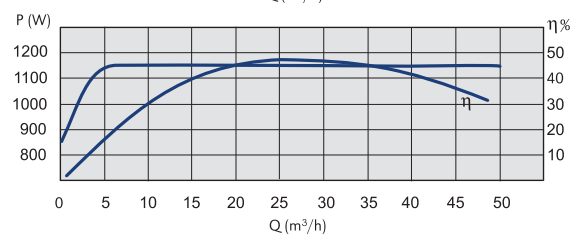
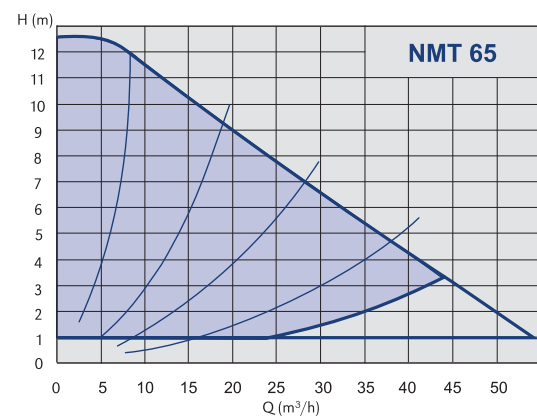

NMT	DN	Fitting length	N. Pressure	Weight	Code	Euro
NMT 65	65	340 mm	PN 6/10 bar	36 kg	979522738	1.764,00 €
NMTD 65	65	340 mm	PN 6/10 bar	63 kg	979522746	3.440,00 €
NMT SAN 65	65	340 mm	PN 6/10 bar	38,5 kg	979523201	2.437,00 €

Dimensions	h	DN	b1	b4	l	a
NMT 65	340	65	189		369	80
NMTD 65	340	65		452	369	80
NMT SAN 65	340	65	189		369	80

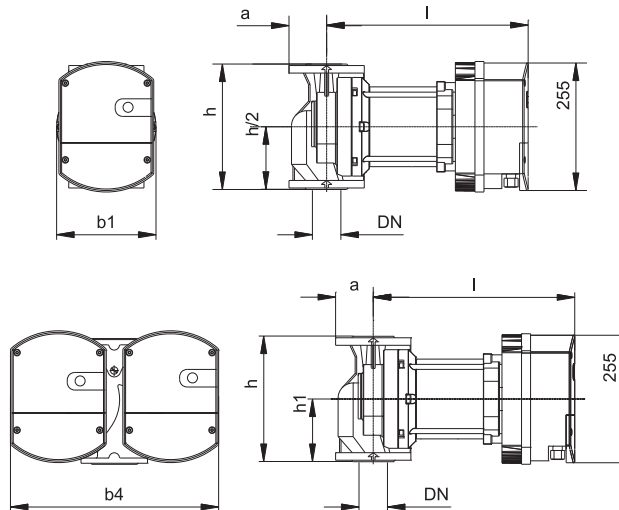

TECHNICAL DATA

Flow Q up to 65 m³/h
 Pressure H up to 13 m
 Power 38 - 1100 Watt
 Nominal pressure 6/10 bar

Permissible mediums

- Water, mixed with glycol, parameters must be checked in the mixture of water with over 20% of glycol
- Pure non-explosive liquid media free from mineral oils and without solid particles

Permissible temperature range

- Medium temperature from -10 °C to +110 °C with max. surroundings temperature up to +40 °C

Minimum inlet pressure

0,5 bar < 50°C Temperature of medium
 0,8 bar < 80°C Temperature of medium
 1,4 bar < 110°C Temperature of medium

Electrical connection

Voltage 1 ~ 230 V, 50/60 Hz

Motor/Electronics

- Motor with permanent magnets
- The energy index EEI ≤ 0,25
- Built-in motor protection
- Methods of control:
 - Current control (limit current)
 - Power control (limit power)
 - Constant pressure control (Δp-c)
 - Proportional pressure control (Δp-v)
 - Option settings QH curve at fixed speeds
 - Constant speed
- Degree of protection: IP 44
- Insulation class H



HIGH-EFFICIENCY REGULATED FLANGED PUMP NMT 80 F

NMT

PERFORMANCE

High efficiency ECM motor series pumps with canned motor and permanent magnets. Variable and constant pressure control through Ethernet connection. For use in water system according to requirements of VDI 2035.

APPLICATIONS

Heating system, air condition systems, closed loop cooling system and industrial circulatory systems. With bronze casting - SAN version, for use in drinking water circulation systems.

OPERATION

Δp -Proportional pressure control

The pump proportionally adjust the pressure, according to system resistance. Guaranteeing minimal power and energy consumptions.

PRODUCT DESCRIPTION

- Efficiency ECM technology
- Energy savings
- Easy handling and installation
- Robust and compact construction for long life
- Automatic venting
- Silent operation
- Possibility of housing with cataphoresis
- Twin pump option
- Twin pump option with SAN - bronze housing

Pump component	Material
Housing	Cast iron
Impeller	Stainless steel
Shaft	Stainless steel
Bearings	Graphite
Separating bush	Stainless steel
Rotor can	Stainless steel

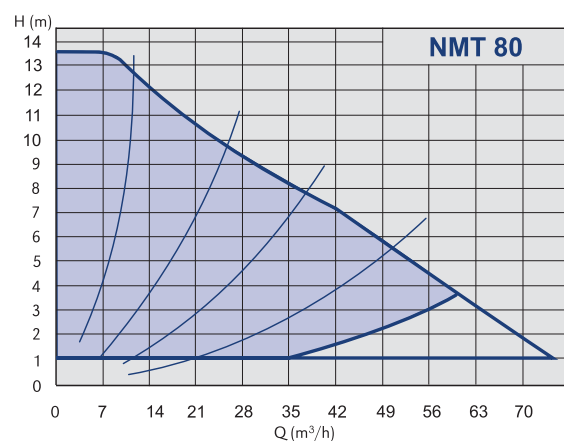

NMT	DN	Fitting length	N. Pressure	Weight	Code	Euro
NMT 80	80	360 mm	PN 6 bar	44 kg	979522739	2.184,00 €
NMT 80	80	360 mm	PN 10 bar	44 kg	979522740	2.184,00 €
NMTD 80	80	360 mm	PN 6 bar	81 kg	979522747	4.259,00 €
NMTD 80	80	360 mm	PN 10 bar	81 kg	979522748	4.259,00 €

Dimensions	h	DN	b1	b4	l	a
NMT 80	360	80	189		403	100
NMTD 80	360	80		462	403	100

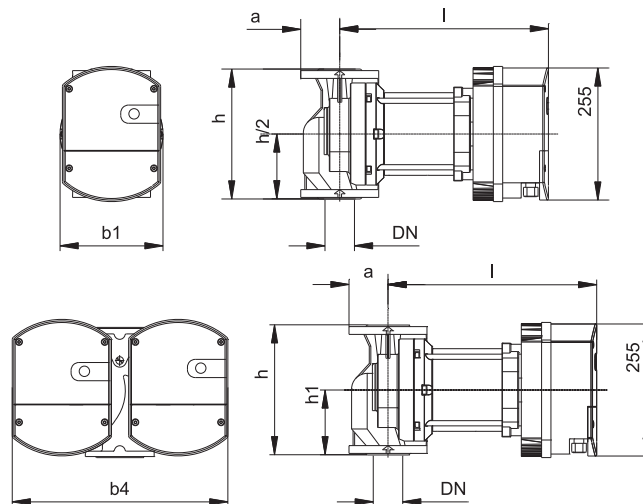

TECHNICAL DATA

Flow Q up to 78 m³/h
 Pressure H up to 13 m
 Power 45 - 1600 Watt
 Nominal pressure PN6 or PN10

Permissible mediums

- Water, mixed with glycol, parameters must be checked in the mixture of water with over 20% of glycol
- Pure non-explosive liquid media free from mineral oils and without solid particles

Permissible temperature range

- Medium temperature from -10 °C to +110 °C with max. surroundings temperature up to +40 °C

Minimum inlet pressure

0,5 bar < 50°C Temperature of medium
 0,8 bar < 80°C Temperature of medium
 1,4 bar < 110°C Temperature of medium

Electrical connection

Voltage 1 ~ 230 V, 50/60 Hz

Motor/Electronics

- Motor with permanent magnets
- The energy index EEI ≤ 0,23
- Built-in motor protection
- Methods of control:
 - Current control (limit current)
 - Power control (limit power)
 - Constant pressure control (Δp-c)
 - Proportional pressure control (Δp-v)
 - Option settings QH curve at fixed speeds
 - Constant speed
- Degree of protection: IP 44
- Insulation class H



HIGH-EFFICIENCY REGULATED FLANGED PUMP NMT 100 F

NMT

PERFORMANCE

High efficiency ECM motor series pumps with canned motor and permanent magnets. Variable and constant pressure control through Ethernet connection. For use in water system according to requirements of VDI 2035.

APPLICATIONS

Heating system, air condition systems, closed loop cooling system and industrial circulatory systems. With bronze casting - SAN version, for use in drinking water circulation systems.

OPERATION

Δp -Proportional pressure control

The pump proportionally adjust the pressure, according to system resistance. Guaranteeing minimal power and energy consumptions.

PRODUCT DESCRIPTION

- Efficiency ECM technology
- Energy savings
- Easy handling and installation
- Robust and compact construction for long life
- Automatic venting
- Silent operation
- Possibility of housing with cataphoresis
- Twin pump option
- Twin pump option with SAN - bronze housing

Pump component	Material
Housing	Cast iron
Impeller	Stainless steel
Shaft	Stainless steel
Bearings	Graphite
Separating bush	Stainless steel
Rotor can	Stainless steel

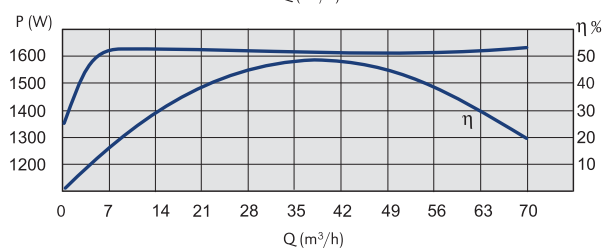
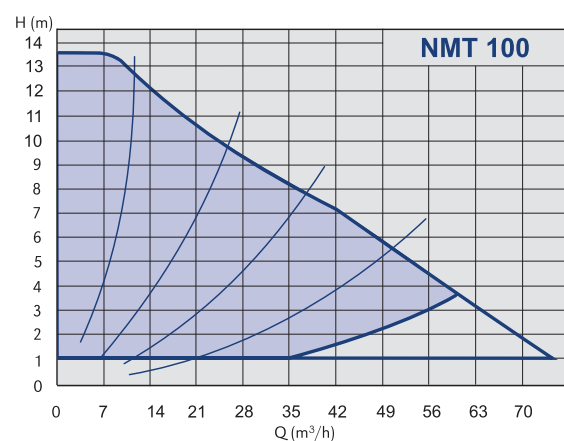

NMT	DN	Fitting length	N. Pressure	Weight	Code	Euro
NMT 100	100	360 mm	PN 6 bar	47 kg	979522762	2.293,00 €
NMT 100	100	360 mm	PN 10 bar	47 kg	979522763	2.293,00 €
Dimensions	L	DN	A	B	C	
NMT 100	360	80	189	403	110	

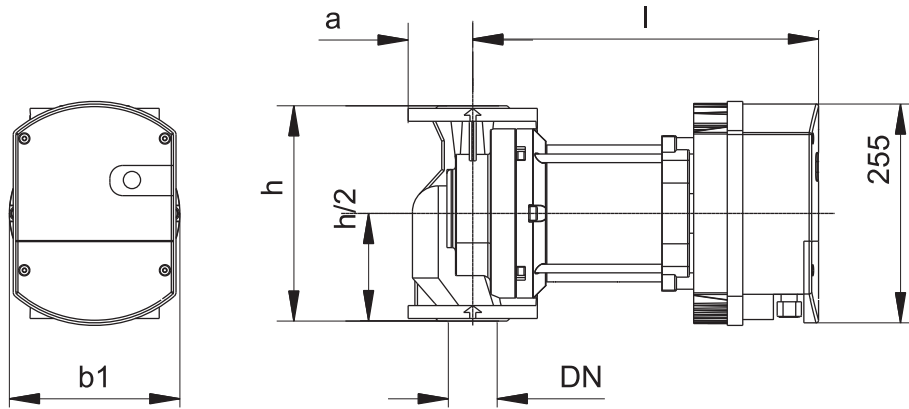

TECHNICAL DATA

Flow Q up to 78 m³/h
 Pressure H up to 13 m
 Power 45 - 1600 Watt
 Nominal pressure PN6 or PN10

Permissible mediums

- Water, mixed with glycol, parameters must be checked in the mixture of water with over 20% of glycol
- Pure non-explosive liquid media free from mineral oils and without solid particles

Permissible temperature range

- Medium temperature from -10 °C to +110 °C with max. surroundings temperature up to +40 °C

Minimum inlet pressure

0,5 bar < 50°C Temperature of medium
 0,8 bar < 80°C Temperature of medium
 1,4 bar < 110°C Temperature of medium

Electrical connection

Voltage 1 ~ 230 V, 50/60 Hz

Motor/Electronics

- Motor with permanent magnets
- The energy index EEI ≤ 0,23
- Built-in motor protection
- Methods of control:
 - Current control (limit current)
 - Power control (limit power)
 - Constant pressure control ($\Delta p-c$)
 - Proportional pressure control ($\Delta p-v$)
 - Option settings QH curve at fixed speeds
 - Constant speed
- Degree of protection: IP 44
- Insulation class H



NEW

HIGH-EFFICIENCY REGULATED FLANGED PUMP NMT LAN 40 F

LAN

PERFORMANCE

High efficiency ECM motor series pumps with canned motor and permanent magnets. Variable and constant pressure control through Ethernet connection and display. For use in water system according to requirements of VDI 2035.

APPLICATIONS

All heating systems, air condition systems, closed loop cooling systems and industrial circulatory systems.

OPERATION

- Auto mode (default)
- Proportional pressure control
- Constant pressure control
- Constant speed
- Night mode

PRODUCT DESCRIPTION

- High efficiency ECM technology
- LED Display for control
- Ethernet connection
- Modbus RTU connection
- Analog control input 0 - 10 V
- 3 digital inputs
- 1 relay output
- Possibility of housing with cataphoresis
- Twin pump option
- Twin pump option with SAN - bronze housing

Pump component	Material
Housing	Cast iron
Impeller	Stainless steel
Shaft	Stainless steel
Bearings	Graphite
Separating bush	Stainless steel
Rotor can	Stainless steel

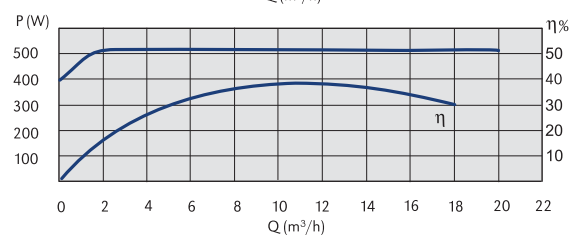
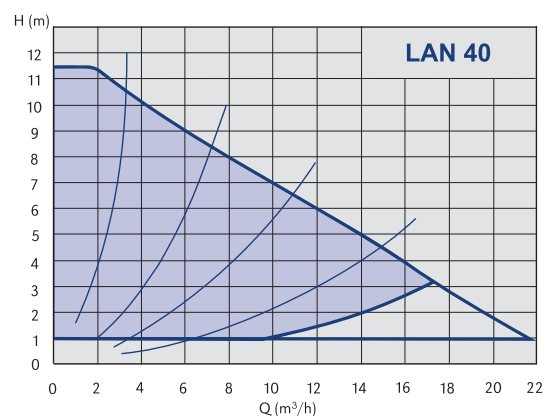

NMT	DN	Fitting length	N. Pressure	Weight	Code	Euro
NMT LAN 40	40	250 mm	PN 6/10 bar	24 kg	2013	2013
NMTD LAN 40	40	250 mm	PN 6/10 bar	47 kg	2013	2013
NMT SAN LAN 40	40	250 mm	PN 6/10 bar	26 kg	2013	2013

Dimensions	L	DN	A	B	C	a
NMT LAN 40	250	40	189		321	65
NMTD LAN 40	250	40		403	321	65
NMT SAN LAN 40	250	40	189		321	65

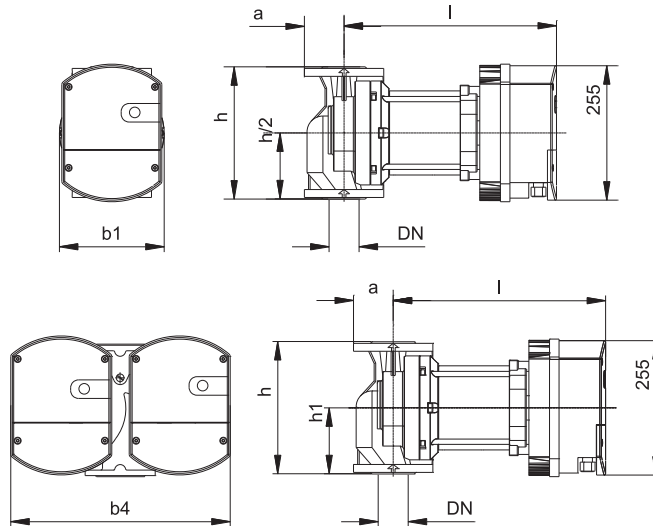

TECHNICAL DATA

Flow Q up to 25 m³/h
 Pressure H up to 13 m
 Power 20 - 500 Watt
 Nominal pressure 6/10 bar

Permissible mediums

- Water, mixed with glycol, parameters must be checked in the mixture of water with over 20% of glycol
- Pure non-explosive liquid media free from mineral oils and without solid particles

Permissible temperature range

- Medium temperature from -10 °C to +110 °C with max. surroundings temperature up to +40 °C

Minimum inlet pressure

0,5 bar < 50°C Temperature of medium
 0,8 bar < 80°C Temperature of medium
 1,4 bar < 110°C Temperature of medium

Electrical connection

Voltage 1 ~ 230 V, 50/60 Hz

Motor/Electronics

- Motor with permanent magnets
- The energy index EEI ≤ 0,27
- Built-in motor protection
- Methods of control:
 - Current control (limit current)
 - Power control (limit power)
 - Constant pressure control (Δp-c)
 - Dp prop (Δp-v)
 - Option settings QH curve at fixed speeds
 - Constant speed
- Degree of protection: IP 44
- Insulation class H



NEW

HIGH-EFFICIENCY REGULATED FLANGED PUMP NMT LAN 50 F

PERFORMANCE

High efficiency ECM motor series pumps with canned motor and permanent magnets. Variable and constant pressure control through Ethernet connection and display. For use in water system according to requirements of VDI 2035.

APPLICATIONS

All heating systems, air condition systems, closed loop cooling systems and industrial circulatory systems.

OPERATION

- Auto mode (default)
- Proportional pressure control
- Constant pressure control
- Constant speed
- Night mode

PRODUCT DESCRIPTION

- High efficiency ECM technology
- LED Display for control
- Ethernet connection
- Modbus RTU connection
- Analog control input 0 - 10 V
- 3 digital inputs
- 1 relay output
- Possibility of housing with cataphoresis
- Twin pump option
- Twin pump option with SAN - bronze housing

Pump component	Material
Housing	Cast iron
Impeller	Stainless steel
Shaft	Stainless steel
Bearings	Graphite
Separating bush	Stainless steel
Rotor can	Stainless steel

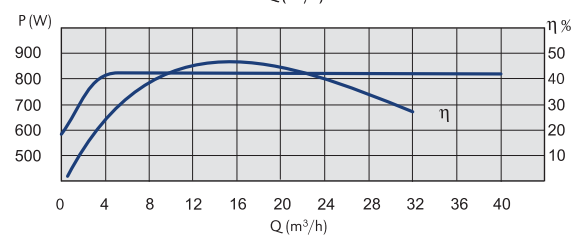
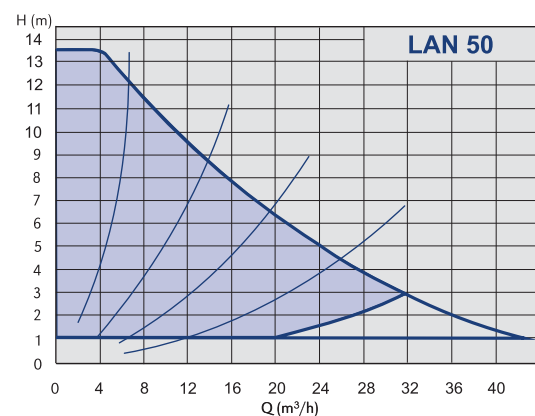

NMT	DN	Fitting length	N. Pressure	Weight	Code	Euro
NMT LAN 50	50	280 mm	PN 6/10 bar	31 kg	2013	2013
NMTD LAN 50	50	280 mm	PN 6/10 bar	60 kg	2013	2013
NMT SAN LAN 50	50	280 mm	PN 6/10 bar	33 kg	2013	2013

Dimensions	L	DN	A	B	C	a
NMT LAN 50	280	50	189		355	70
NMTD LAN 50	280	50		403	355	70
NMT SAN LAN 50	280	50	189		355	70

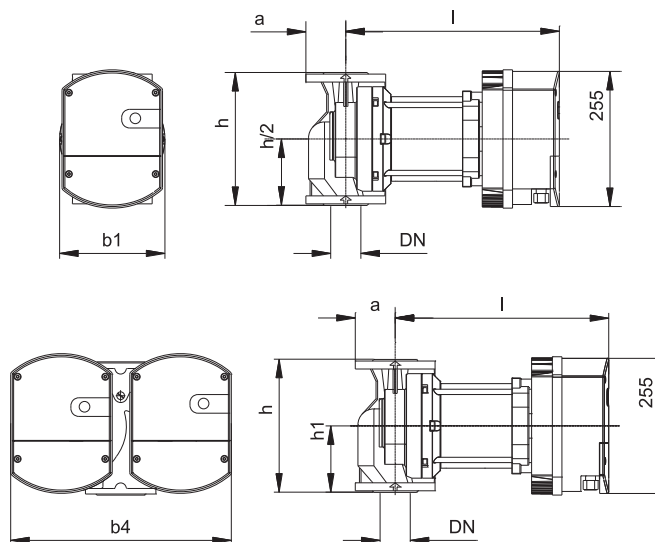

TECHNICAL DATA

Flow Q up to 39 m³/h
 Pressure H up to 13 m
 Power 26 - 800 Watt
 Nominal pressure 6/10 bar

Permissible mediums

- Water, mixed with glycol, parameters must be checked in the mixture of water with over 20% of glycol
- Pure non-explosive liquid media free from mineral oils and without solid particles

Permissible temperature range

- Medium temperature from -10 °C to +110 °C with max. surroundings temperature up to +40 °C

Minimum inlet pressure

0,5 bar < 50°C Temperature of medium
 0,8 bar < 80°C Temperature of medium
 1,4 bar < 110°C Temperature of medium

Electrical connection

Voltage 1 ~ 230 V, 50/60 Hz

Motor/Electronics

- Motor with permanent magnets
- The energy index EEI ≤ 0,26
- Built-in motor protection
- Methods of control:
 - Current control (limit current)
 - Power control (limit power)
 - Constant pressure control (Δp-c)
 - Dp prop (Δp-v)
 - Option settings QH curve at fixed speeds
 - Constant speed
- Degree of protection: IP 44
- Insulation class H



HIGH-EFFICIENCY REGULATED FLANGED PUMP NMT LAN 65 F

LAN

PERFORMANCE

High efficiency ECM motor series pumps with canned motor and permanent magnets. Variable and constant pressure control through Ethernet connection and display. For use in water system according to requirements of VDI 2035.

APPLICATIONS

All heating systems, air condition systems, closed loop cooling systems and industrial circulatory systems.

OPERATION

- Auto mode (default)
- Proportional pressure control
- Constant pressure control
- Constant speed
- Night mode

PRODUCT DESCRIPTION

- High efficiency ECM technology
- LED Display for control
- Ethernet connection
- Modbus RTU connection
- Analog control input 0 - 10 V
- 3 digital inputs
- 1 relay output
- Possibility of housing with cataphoresis
- Twin pump option
- Twin pump option with SAN - bronze housing

Pump component	Material
Housing	Cast iron
Impeller	Stainless steel
Shaft	Stainless steel
Bearings	Graphite
Separating bush	Stainless steel
Rotor can	Stainless steel

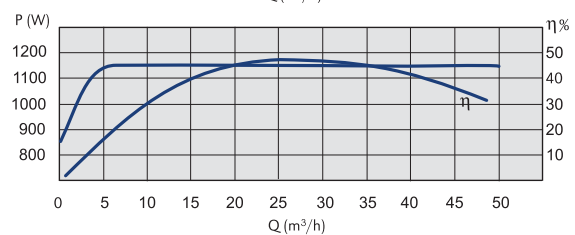
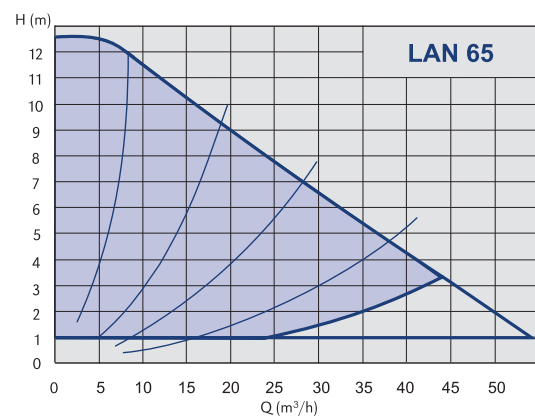

NMT	DN	Fitting length	N. Pressure	Weight	Code	Euro
NMT LAN 65	65	340 mm	PN 6/10 bar	36 kg	2013	2013
NMTD LAN 65	65	340 mm	PN 6/10 bar	63 kg	2013	2013
NMT SAN LAN 65	65	340 mm	PN 6/10 bar	38,5 kg	2013	2013

Dimensions	L	DN	A	B	C	a
NMT LAN 65	340	65	189		369	80
NMTD LAN 65	340	65		452	369	80
NMT SAN LAN 65	340	65	189		369	80

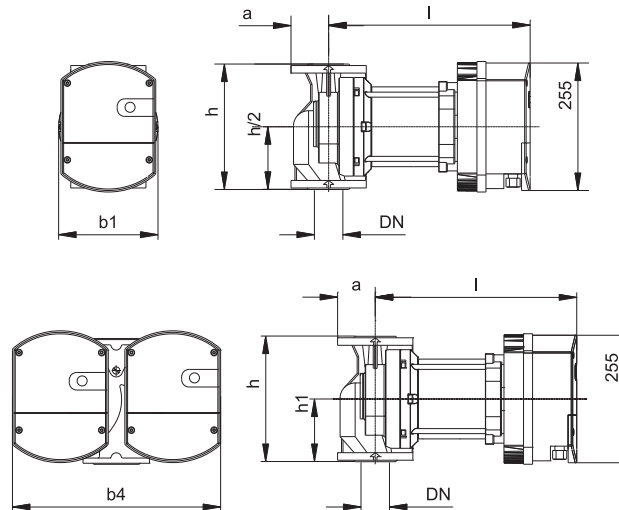

TECHNICAL DATA

Flow Q up to 65 m³/h
 Pressure H up to 13 m
 Power 38 - 1100 Watt
 Nominal pressure 6/10 bar

Permissible mediums

- Water, mixed with glycol, parameters must be checked in the mixture of water with over 20% of glycol
- Pure non-explosive liquid media free from mineral oils and without solid particles

Permissible temperature range

- Medium temperature from -10 °C to +110 °C with max. surroundings temperature up to +40 °C

Minimum inlet pressure

0,5 bar < 50°C Temperature of medium
 0,8 bar < 80°C Temperature of medium
 1,4 bar < 110°C Temperature of medium

Electrical connection

Voltage 1 ~ 230 V, 50/60 Hz

Motor/Electronics

- Motor with permanent magnets
- The energy index EEI ≤ 0,25
- Built-in motor protection
- Methods of control:
 - Current control (limit current)
 - Power control (limit power)
 - Constant pressure control (Δp-c)
 - Dp prop (Δp-v)
 - Option settings QH curve at fixed speeds
 - Constant speed
- Degree of protection: IP 44
- Insulation class H



NEW

HIGH-EFFICIENCY REGULATED FLANGED PUMP NMT LAN 80 F

PERFORMANCE

High efficiency ECM motor series pumps with canned motor and permanent magnets. Variable and constant pressure control through Ethernet connection and display. For use in water system according to requirements of VDI 2035.

APPLICATIONS

All heating systems, air condition systems, closed loop cooling systems and industrial circulatory systems.

OPERATION

- Auto mode (default)
- Proportional pressure control
- Constant pressure control
- Constant speed
- Night mode

PRODUCT DESCRIPTION

- High efficiency ECM technology
- LED Display for control
- Ethernet connection
- Modbus RTU connection
- Analog control input 0 - 10 V
- 3 digital inputs
- 1 relay output
- Possibility of housing with cataphoresis
- Twin pump option
- Twin pump option with SAN - bronze housing

Pump component	Material
Housing	Cast iron
Impeller	Stainless steel
Shaft	Stainless steel
Bearings	Graphite
Separating bush	Stainless steel
Rotor can	Stainless steel

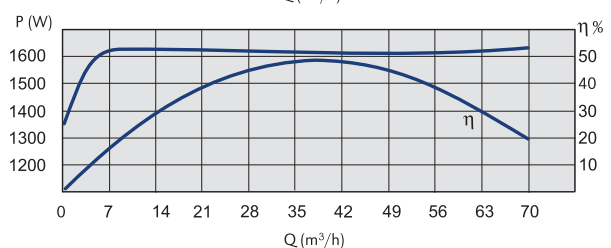
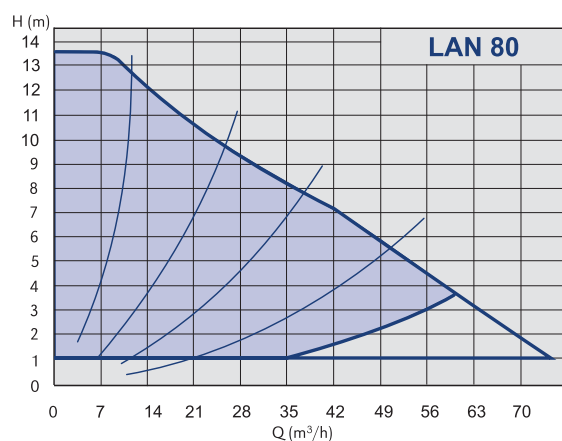

NMT	DN	Fitting length	N. Pressure	Weight	Code	Euro
NMT LAN 80	80	360 mm	PN 6 bar	44 kg	2013	2013
NMT LAN 80	80	360 mm	PN 10 bar	44 kg	2013	2013
NMTD LAN 80	80	360 mm	PN 6 bar	81 kg	2013	2013
NMTD LAN 80	80	360 mm	PN 10 bar	81 kg	2013	2013

Dimensions	L	DN	A	B	C	a
NMT LAN 80	360	80	189		403	100
NMTD LAN 80	360	80		462	403	100

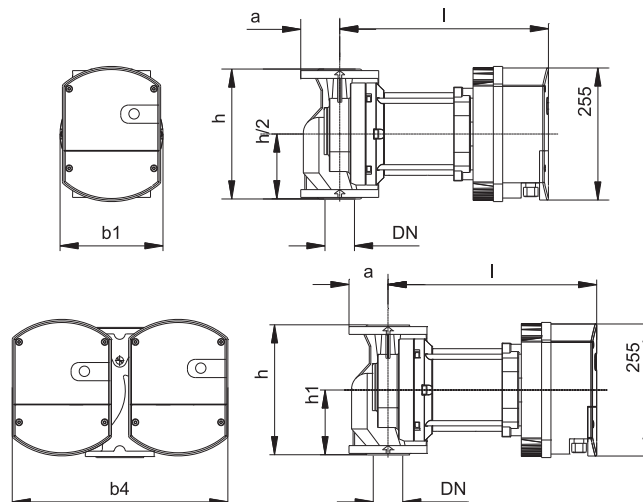

TECHNICAL DATA

Flow Q up to 78 m³/h
 Pressure H up to 13 m
 Power 45 - 1600 Watt
 Nominal pressure PN6 or PN10

Permissible mediums

- Water, mixed with glycol, parameters must be checked in the mixture of water with over 20% of glycol
- Pure non-explosive liquid media free from mineral oils and without solid particles

Permissible temperature range

- Medium temperature from -10 °C to +110 °C with max. surroundings temperature up to +40 °C

Minimum inlet pressure

0,5 bar < 50°C Temperature of medium
 0,8 bar < 80°C Temperature of medium
 1,4 bar < 110°C Temperature of medium

Electrical connection

Voltage 1 ~ 230 V, 50/60 Hz

Motor/Electronics

- Motor with permanent magnets
- The energy index EEI ≤ 0,23
- Built-in motor protection
- Methods of control:
 - Current control (limit current)
 - Power control (limit power)
 - Constant pressure control (Δp-c)
 - Dp prop (Δp-v)
 - Option settings QH curve at fixed speeds
 - Constant speed
- Degree of protection: IP 44
- Insulation class H



ECO HIGH-EFFICIENCY REGULATED PUMPS FOR DOMESTIC HOT WATER

SAN

PERFORMANCE

The high-efficiency, continuously, manually adjustable pump for domestic hot water, freely flowing ball axis permanent magnet motor and ECM technology.

APPLICATIONS

The pump automatically adjust the pressure, according to system resistance.

OPERATION

The pump automatically adjust the pressure, according to system resistance. The timer installation is possible for selecting the starting time of the operation and adjusting the thermostat.

PRODUCT DESCRIPTION

- The high efficiency of the ECM technology
- Energy savings
- 4 possible performances
 - B version with bronze housing
 - BU version with bronze housing and timer
 - BTU model with bronze housing, thermostat and timer
 - GT version with bronze housing and thermostat
- Easy handling and installation
- Robust and compact construction for long life
- Specially adapted to the independence of lime scale
- Easy to use and small

Pump component	Material
Housing	Bronze
Ceramic bearings	Ceramics
Rotor impeler	polyamide

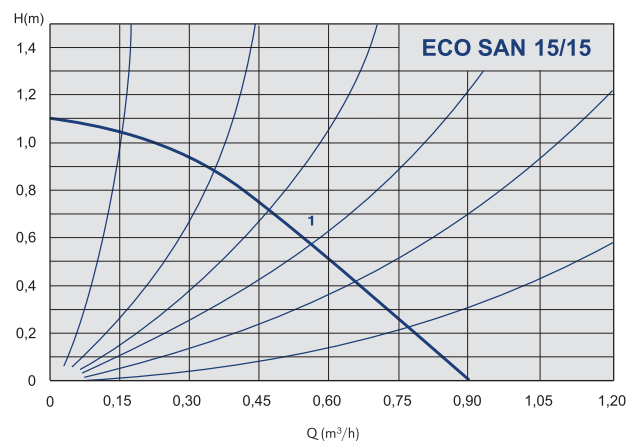

ECO SAN	DN	Fitting length	N. Pressure	Weight	Code	Euro
15/15 B	15	65 mm	PN 10 bar	0,9 kg	979523230	116,00 €
15/15 BU	15	65 mm	PN 10 bar	1,0 kg	979523231	148,00 €
15/15 BTU	15	65 mm	PN 10 bar	1,0 kg	979523232	193,00 €
15/15 BT	15	65 mm	PN 10 bar	1,0 kg	979523233	141,00 €

Dimensions	L	DN	A	B	C
15/15 BT	65 mm	15	163	150	110
15/15 BTU	65 mm	15	163	150	110

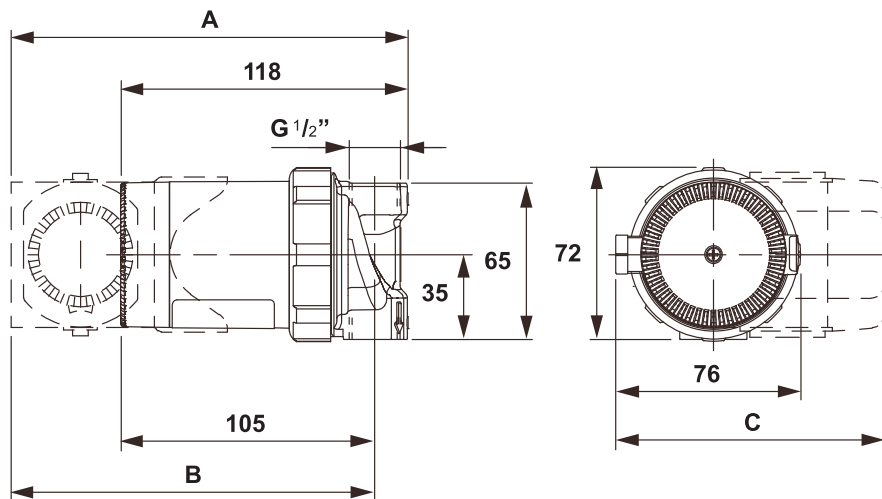

TECHNICAL DATA

Flow Q up to 0,9 m³/h
 Pressure H up to 1,1 m
 Power 2 - 8 Watt
 Nominal pressure 10 bar

Permissible mediums

- Water, mixed with glycol, parameters must be checked in the mixture of water with over 20% of glycol
- Pure non-explosive liquid media free from mineral oils and without solid particles

Permissible temperature range

- Medium temperature to +95°C

Minimum inlet pressure

0,05 bar < 75 °C Temperature of medium
 0,28 bar < 90 °C Temperature of medium

Electrical connection

Voltage 1 ~ 230 V, 50/60 Hz

Motor/Electronics

- Maximum power 8 W
- Shaftless spherical motor with ECM technology
- Protection IP 44
- Insulation class F
- Optional with thermostat for temperature range 20-70 °C
- Optional timer

INSTALLATION

After installing the pump, the motor shafts have to remain in horizontal position.

NMT (SAN)



NMT (SAN)



NMT (SAN)



NMTD (SAN)



THE HONEST PRODUCT FOR THE HONEST PRICE



Your contact

IMPPUMPS[®]

IMP PUMPS, d.o.o.

SI - 1218 Komenda

info@imp-pumps.com

www.imp-pumps.com

Empty rounded rectangular box for contact information.